

OPERATOR'S MANUAL
FOR
TRUCK, FORKLIFT:
ADVERSE TERRAIN,
10,000 LB CAPACITY, M544E
(NSN 3930-01-301-8250)

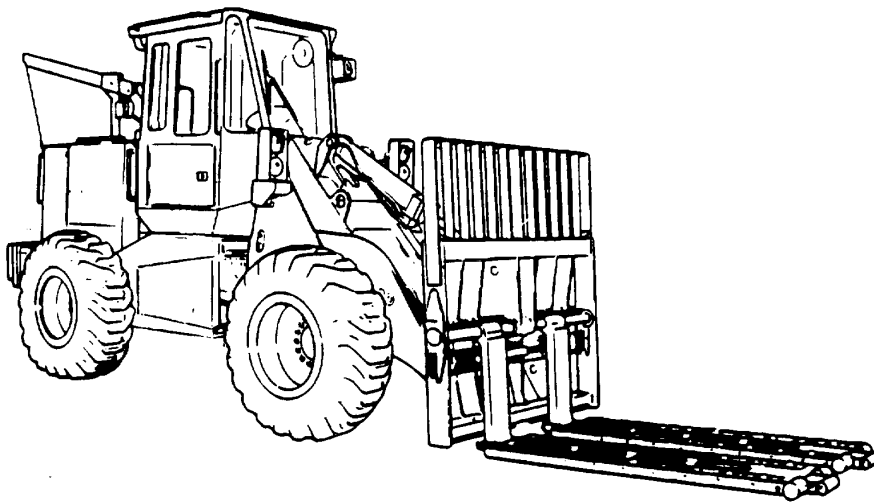

How To Use This Manual	iii
Equipment Description and Data	1-3
Operating Instructions	2-1
Preventive Maintenance Checks and Services (PMCS)	2-11
Troubleshooting Procedures	3-2
Maintenance Procedures	3-11

Approved for public release; distribution is unlimited.

HEADQUARTERS, DEPARTMENT OF THE ARMY

NOVEMBER 1993

**OPERATOR'S MANUAL
FOR
TRUCK, FORKLIFT: ADVERSE TERRAIN,
10,000 LB CAPACITY, M544E
(NSN 3930-01-301-8250)**

REPORTING ERRORS AND RECOMMENDING IMPROVEMENTS

You can help improve this manual. If you find any mistakes or if you know of a way to improve the procedures, please let us know. Mail your letter, DA Form 2028 (*Recommended Changes to Publications and Blank Forms*), or DA Form 2028-2, located in the back of this manual, directly to: Commander, U.S. Army Tank-Automotive Command, ATTN: AMSTA-MB, Warren, MI 48397-5000. A reply will be furnished to you.

TABLE OF CONTENTS

	Page
How To Use This Manual	iii
CHAPTER 1 INTRODUCTION	1-1
Section I. General Information	1-1
Section II. Equipment Description and Data	1-3
Section III. Principles of Operation	1-10
CHAPTER 2 OPERATING INSTRUCTIONS	2-1
Section I. Description and Use of Operator's Controls and Indicators	2-1
Preventive Maintenance Checks and Services (PMCS)	2-1

Approved for public release: distribution is unlimited.

TABLE OF CONTENTS (Con't)

	Page
Section III. Operation Under Usual Conditions.....	2-34
Section IV. Operation Under Unusual Conditions.....	2-65
CHAPTER 3 MAINTENANCE INSTRUCTIONS.....	3-1
Section I. Lubrication Instructions	3-1
Section II. Troubleshooting Procedures.....	3-2
Section III. Maintenance Procedures.....	3-11
APPENDIX A REFERENCES.....	A-1
APPENDIX B COMPONENTS OF END ITEM (COEI) AND BASIC ISSUE ITEMS (BII) LISTS.....	B-1
APPENDIX C ADDITIONAL AUTHORIZATION LIST (AAL).....	C-1
APPENDIX D EXPENDABLE/DURABLE SUPPLIES AND MATERIALS LIST.....	D-1
APPENDIX E STOWAGE AND SIGN GUIDE.....	E-1
INDEX	Index 1

HOW TO USE THIS MANUAL

This manual is designed to operate the M544E Forklift Truck

FEATURES OF THIS MANUAL:

- Bleed-to-edge Indicators on the cover and on the edge of the applicable manual pages provide quick access to chapters and sections most often used.
- WARNINGS, CAUTIONS, NOTES, subject headings, and other important information are highlighted in BOLD print as a visual aid.

WARNING

A WARNING Indicates a hazard which can result in death or serious injury.

CAUTION

A CAUTION is a reminder of safety practices or directs attention to usage practices that may result in damage to equipment.

NOTE

A NOTE is a statement containing information that will make the procedure easier to perform.

- An alphabetized list of abbreviations and their meanings are included in Chapter 1 for reference purposes.

HOW TO USE THIS MANUAL (Con't)

- Instructions are located together with illustrations that show the specific task on which the operator is working.
- Dashed leader lines used in illustrations indicate that called out items are not visible (i.e., they are located *within* the structure). The example illustrates that the drive axles (8) are located within the axle.

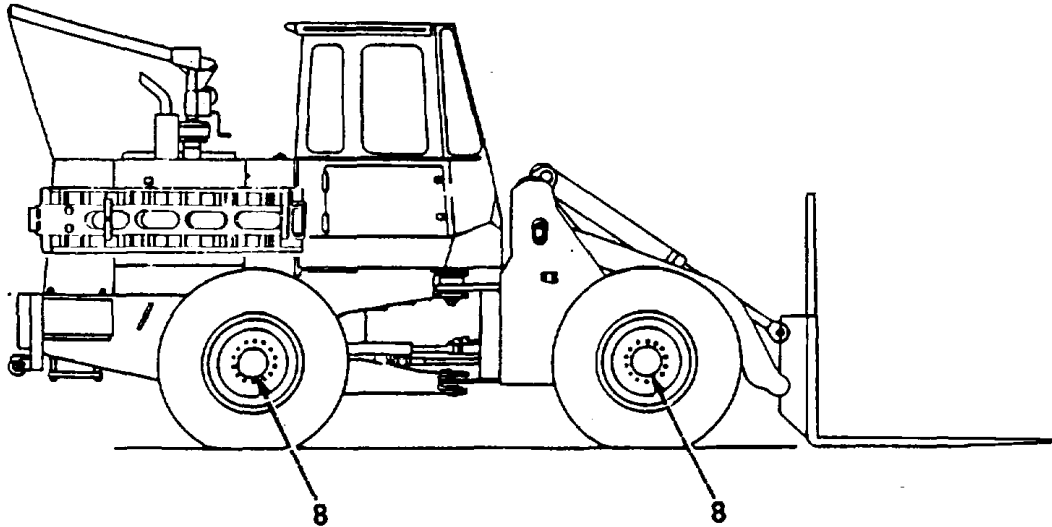

Dasher Leader Line Example

- An alphabetical index is provided at the end of the manual to assist in locating information not readily found in the table of contents.
- Technical instructions include metric units in addition to standard units. A metric conversion chart is provided on the inside back cover.

FOLLOW THESE GUIDELINES WHEN YOU USE THIS MANUAL:

- Read through this manual and become familiar with its contents before attempting to operate this vehicle.
- A warning summary is provided at the beginning of this manual and should be read before attempting to operate this vehicle.
- Within a chapter or section, headings are used to help group the material to assist in quickly finding tasks.

TA704469

FOR INFORMATION ON FIRST AID, REFER TO FM 21-11.

WARNING

CARBON MONOXIDE (EXHAUST GASES) CAN KILL!

Carbon monoxide is a colorless, odorless, deadly poisonous gas which, when breathed, deprives the body of oxygen and causes suffocation. Exposure to air containing carbon monoxide produces symptoms of headache, dizziness, loss of muscular control, apparent drowsiness, and coma. Permanent brain damage or death can result from severe exposure.

Carbon monoxide occurs in exhaust fumes of internal combustion engines. Carbon monoxide can become dangerously concentrated under conditions of inadequate ventilation. The following precautions must be observed to ensure safety of personnel when engine of forklift truck is operated for any purpose.

- (1) DO NOT operate forklift truck engine in enclosed areas.
- (2) DO NOT idle forklift truck engine with cab windows closed and without ventilator blower operating.
- (3) DO NOT drive forklift truck with inspection plates or cover plates removed.
- (4) BE ALERT at all times for exhaust odors.
- (5) BE ALERT for exhaust poisoning symptoms. They are:
 - Headache
 - Dizziness
 - Sleepiness
 - Loss of muscular control
- (6) If you see another person with exhaust poisoning symptoms:
 - Remove person from area.
 - Expose to fresh air.
 - Keep person warm.
 - Do not permit physical exercise.
 - Administer artificial respiration, if necessary.
 - Notify a medic.
- (7) BE AWARE: The field protective mask for chemical-biological-radiological (CBR) protection will not protect you from carbon monoxide poisoning.

The Best Defense Against Carbon Monoxide Poisoning Is Good Ventilation.

WARNING**BATTERIES**

- **Remove all jewelry such as rings, dog tags, bracelets, etc. If jewelry contacts battery terminal, a direct short will result, causing Instant heating of jewelry which will result in severe Injury to personnel.**
- **Battery gases can explode. DO NOT smoke or allow sparks or open flames near batteries. Wear safety glasses or goggles when checking batteries. Failure to follow this warning may result in death or serious Injury to personnel.**
- **Sulfuric acid contained in batteries can cause serious burns. If battery corrosion or electrolyte makes contact with skin, eyes, or clothing, take immediate action to stop the corrosive burning effects. Failure to follow these procedures may result in death or serious injury to personnel.**
 - a. Eyes. Flush with cold water for no less than 15 minutes and seek medical attention immediately.
 - b. Skin. Flush with large amounts of cold water until all acid is removed. Seek medical attention as required.
 - c. Internal. If corrosion or electrolyte is Ingested, drink large amounts of water or milk. Follow with milk of magnesia, beaten egg, or vegetable oil. Seek medical attention Immediately.
 - d. Clothing/Equipment. Wash area with large amounts of cold water. Neutralize acid with baking soda or household ammonia.

WARNING**COMPRESSED AIR**

Compressed air used for cleaning or drying purposes, or for cleaning restrictions, should never exceed 30 psi (207 kPa). Wear protective clothing (goggles/shield, gloves, etc.) and use caution to avoid injury to personnel.

b

WARNING

DIESEL FUEL HANDLING

- **DO NOT** smoke or permit any open flame in area of forklift truck while you are servicing diesel fuel system. Be sure hose nozzle is grounded against filler tube during refueling to prevent static electricity. Failure to follow this warning will result in injury to personnel or equipment damage.
- Diesel fuel is combustible. **DO NOT** smoke or allow open flame near fuel tank. Failure to follow this warning will result in death or serious injury to personnel. If you are burned, immediately seek medical aid.

WARNING

ENGINE OPERATION

Start engine only while properly seated on operator's seat, seatbelt fastened, cab door and cab right window latched in desired position, and mirror adjusted. Failure to follow this warning may result in injury or death to operator or nearby personnel.

WARNING

EXHAUST PIPE AND MUFFLER

DO NOT touch hot exhaust pipe or muffler with bare hands. Severe injury to personnel will result.

WARNING

FORKLIFT OPERATION

Never allow forks or load to contact power lines. If forklift truck must be operated in vicinity of power lines, follow these safety precautions. Failure to follow these procedures may result in death or serious injury.

- a. Contact power company and have all power lines and ground wires turned off.
- b. DO NOT allow any portion of equipment close to power lines.
- c. Know maximum height and reach of forklift truck and build a suitable barricade around all power sources.
- d. Warn all personnel in work area of power source and electrocution hazard.
- e. If contact with a power source does occur, DO NOT step off the forklift truck. Stay on the vehicle until power is turned off or equipment is lowered and clear of power source.
- f. If fire or other conditions force operator to leave the forklift truck, Jump off and away keeping all parts of body clear of the equipment.

WARNING

ON-BOARD CRANE OPERATION

Crane is heavy. Assistant is required to raise or lower crane to various operating positions. Assistant may be required to help raise or lower load. Failure to follow this warning may result in injury to personnel.

WARNING

PARKING FORKLIFT TRUCK

DO NOT depend on direction selector lever alone to keep forklift truck from moving. ALWAYS apply parking brake. Failure to follow this warning may result in injury to personnel.

WARNING

NBC EXPOSURE

If NBC exposure is suspected, all engine air cleaner air filter media should be handled by personnel wearing protective equipment. Consult your NBC Officer or NBC NCO for appropriate handling or disposal procedures.

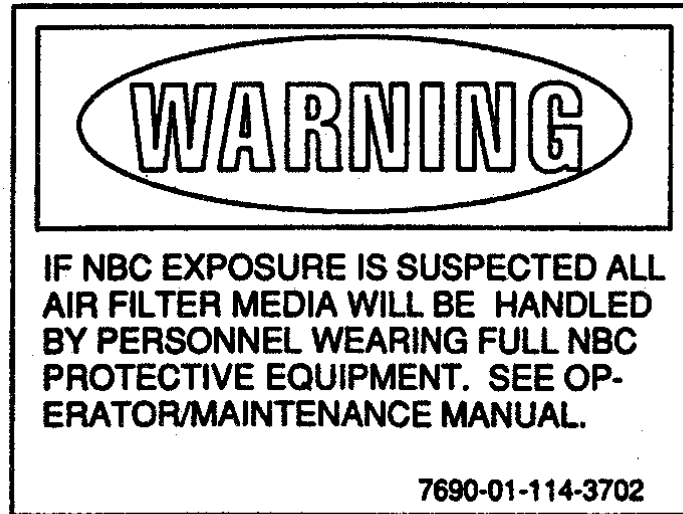

To order this NBC decal use:

National Stock Number (NSN) - 7690-01-114-3702

Part Number (PN) - 12296626

Commercial and Government Entity Code (CAGEC) - 19207

WARNING

PASSENGERS

DO NOT allow passengers to ride in cab or outside cab on forklift truck. Injury to personnel may result.

WARNING

PRESSURIZED COOLING SYSTEM

DO NOT remove radiator fill cap unless engine is cold. This is a pressurized cooling system and escaping steam, hot water, or coolant will cause serious burns.

WARNING

SLAVE STARTING FORKLIFT TRUCK

- When slave starting forklift truck, use NATO slave cables that DO NOT have loose or missing Insulation.
- DO NOT slave start vehicle if suitable cables are not available.
- DO NOT use civilian-type jumper cables.

WARNING

STARTING FLUID

Starting fluid is toxic and highly flammable. Container is pressurized to act as an expellant. DO NOT heat container and DO NOT discharge starting fluid in confined areas or near an open flame. Failure to follow this procedure may result in serious injury to personnel.

WARNING

VEHICLE MOVEMENT

- Before moving forklift truck, ensure that all personnel are away from danger areas of forklift truck. Specifically, check to ensure that no one is between forward and rear sections of forklift truck. Failure to follow this warning may result in injury or death to personnel.
- DO NOT move forklift truck with frame locking bar in place. Forklift will be unsteerable and may result in injury to personnel.

CHAPTER 1 INTRODUCTION

Section I. GENERAL INFORMATION

1-1. SCOPE.

- a. **Type of Manual.** Operator's Manual.
- b. **Equipment Name and Model Number.** Truck, Forklift: Adverse Terrain, 10, 000 Lb Capacity, M544E.
- c. **Purpose of Equipment.** The forklift truck is designed for conventional loading and unloading or stacking and unstacking of suitably packaged materiel.

1-2. MAINTENANCE FORMS AND PROCEDURES.

Department of the Army forms and procedures used for the equipment will be those prescribed by DA Pam 738-750, *The Army Maintenance Management System (TAMMS) Maintenance Management*.

1-3. CORROSION PREVENTION AND CONTROL.

a. Corrosion Prevention and Control (CPC) of Army materiel is a continuing concern. It is important that any corrosion problems with this item be reported so that the problem can be corrected and improvements can be made to prevent the problem in future items.

b. While corrosion is typically associated with rusting of metals, it can also include deterioration of other materials, such as rubber and plastic. Unusual cracking, softening, swelling, or breaking of these materials may be a corrosion problem.

c. If a corrosion problem is identified, it can be reported using SF Form 368 (*Product Quality Deficiency Report*). Use of key words such as "corrosion," "rust," "deterioration," or "cracking" will ensure that the information is identified as a CPC problem. The form should be submitted to the address specified in DA Pam 738-750.

1-4. DESTRUCTION OF ARMY MATERIEL TO PREVENT ENEMY USE.

For destruction of Army materiel to prevent enemy use, refer to TM 750-244-3.

1-5. REPORTING EQUIPMENT IMPROVEMENT RECOMMENDATIONS (EIRs).

If your forklift truck needs improvement, let us know. Send us an EIR. You, the user, are the only one who can tell us what you don't like about your equipment. Let us know why you don't like the design. Put it on an SF Form 368 (*Product Quality Deficiency Report*). Mail it to us at: Commander, U.S. Army Tank-Automotive Command, ATTN: AMSTA-MP, Warren, MI 48397-5000. We'll send you a reply.

1-6. WARRANTY INFORMATION.

The forklift truck is under warranty by the John Deere Company in accordance with TB 10-3930-659-14.

1-7. LIST OF ABBREVIATIONS.

cm.....	Centimeter
CPC.....	Corrosion Prevention and Control
cu in.....	Cubic Inch
EIR.....	Equipment Improvement Recommendation
gl.....	Gallon
gpm.....	Gallons Per Minute
in.....	Inch
kg.....	Kilogram
kPa.....	KiloPascal
kph.....	Kilometers Per Hour
l.....	Liter
lb.....	Pound
mm.....	Millimeter
mph.....	Miles Per Hour
psi.....	Pounds Per Square Inch
rpm.....	Revolutions Per Minute
SF Form.....	Standard Form
TAMMS.....	The Army Maintenance Management System
qt.....	Quart

Section II. EQUIPMENT DESCRIPTION AND DATA**1-8. EQUIPMENT CHARACTERISTICS, CAPABILITIES, AND FEATURES.**

- a. The forklift truck is a commercial adverse terrain vehicle designed for loading and unloading or stacking and unstacking of suitably packaged materiel.
- b. The forklift truck has a lifting capacity of 10, 000 pounds for raising, lowering, and transporting loads.
- c. Features of the forklift truck:
 - (1) Turbocharged six-cylinder diesel engine.
 - (2) Power shift transmission with four forward and three reverse speeds.
 - (3) Full-time four-wheel drive.
 - (4) Articulating frame steering.
 - (5) Removable cab assembly to facilitate air transport.
 - (6) Conveyorized fork attachment.
 - (7) On-board crane to facilitate the removal and installation of the cab, counterweight, and conveyorized fork attachment.
 - (8) A 24-volt electrical system capable of operating under standard and blackout modes.
 - (9) A NATO slave cable receptacle for slave starting the engine.
 - (10) Air compressor to facilitate inflation of the forklift truck tires under emergency conditions.
 - (11) Winterization package to protect the vehicle systems down to -65°F (-54 °C).

1-9. LOCATION AND DESCRIPTION OF MAJOR COMPONENTS.

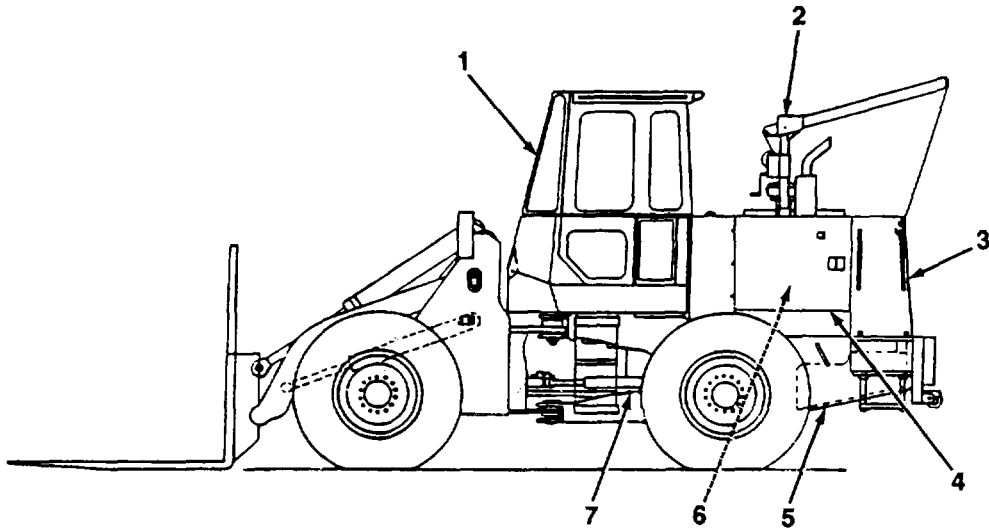

KEY	Component	FUNCTION	
1	Cab	Cab assembly has two sections. The upper section is removed for air transport. Used to remove and install the cab upper section, counterweight, and conveyORIZED fork attachment. Hand-operated, 900 lb capacity.	
2	On-board Crane		Provide engine and hydraulic system cooling and Shroud
3	Radiator Grille		Provides access to service engine.
4	Engine Service Door		Has 55 gal capacity.
5	Fuel Tank		Is a 6-cylinder In-line turbocharged diesel.
6	Engine		Has multirange power shift.
7	Transmission		

TA704470

1-9. LOCATION AND DESCRIPTION OF MAJOR COMPONENTS (Con't).

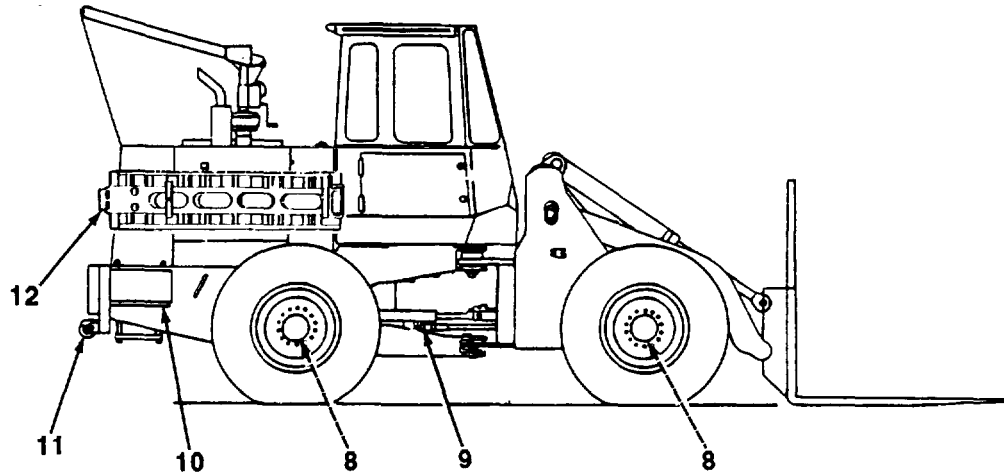

KEY	Component	FUNCTION
8	Drive Axles	Has inboard planetary with bevel gear differential.
9	Steering Cylinders	Are hydraulic cylinders for the articulating frame steering.
10	Battery Box	Provides storage for 12-volt battery.
11	Pintle Hook	Used for towing.
12	Stowage Point for Conveyorized Fork Attachment	Used for stowing conveyorized fork attachment when not installed on forks.

TA704471

1-9. LOCATION AND DESCRIPTION OF MAJOR COMPONENTS (Con't).

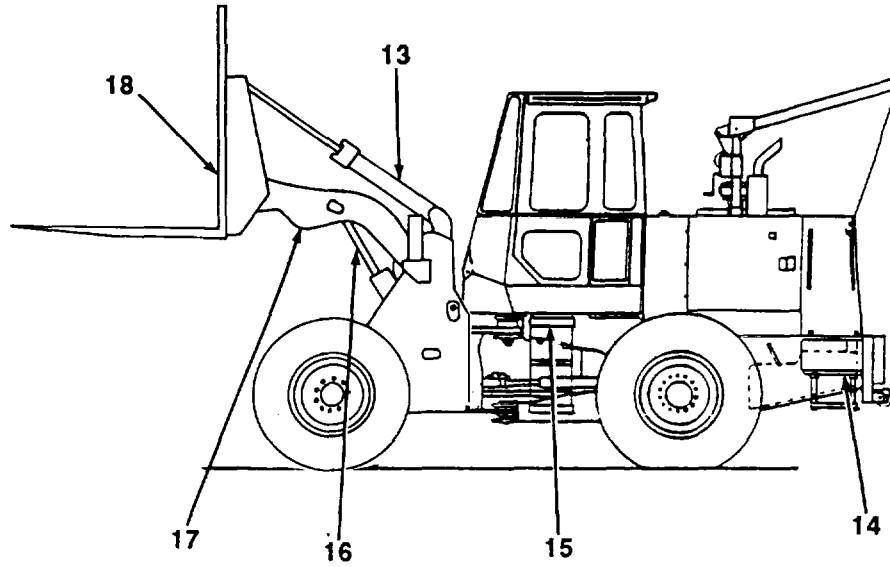

KEY	Component	FUNCTION
13	Fork Tilt Cylinder	Tilts the fork carriage using hydraulic cylinder.
14	Battery Box	Provides storage for 12-volt battery.
15	Locking Bar	Locks the articulating frame.
16	Fork Boom Cylinders	Raise and lower the fork carriage using hydraulic cylinders.
17	Boom Frame	Supports and attaches hydraulic cylinders and fork carriage.
18	Fork Carriage	Secures loads during forklift operations using hydraulically controlled forks and metal backrest.

TA704472

1-10. EQUIPMENT DATA.

Table 1-1. General Characteristics and Specifications.

General Vehicle Specifications:	
Lifting Capacity	10, 000 lb (4540 kg)
Vehicle Weight	24, 220 lb (10996 kg)
Overall:	
Length	303 in. (769.6 cm)
Width	100 in. (254.0 cm)
Height (Boom Raised).....	190 in. (482.6 cm)
Wheelbase	114 in. (289.6 cm)
Wheel Tread.....	83 in. (210.8 cm)
Ground Clearance	16 in. (40.6 cm)
Steering Radius.....	195 in. (495.3 cm)
Load Lift Height	75 in. (190.5 cm)
Travel Speeds (Maximum):	
Forward Gears:	
First	4.5 mph (7.2 kph)
Second.....	7.6 mph (12.2 kph)
Third.....	17.2 mph (27.7 kph)
Fourth.....	24.6 mph (39.6 kph)
Reverse Gears:	
First	4.5 mph (7.2 kph)
Second.....	7.6 mph (12.2 kph)
Third.....	17.2 mph (27.7 kph)
Fluid Capacities:	
Fuel Tank	55 gal (208 l)
Engine:	
Oil.....	20qt(18.9)
Coolant.....	25 qt (23.7 l)
Transmission Oil.....	10 qt (9.4 l)
Differential Oil (Each)	17 qt (16 l)
Hydraulic Reservoir	20 gal (76 l)
Engine Specifications:	
Engine Type	John Deere Turbocharged Diesel
Cycle.....	Four
Number of Cylinders.....	Six
Piston Displacement.....	359 cu in.

1-10. EQUIPMENT DATA (Con't).

Table 1-1. General Characteristics and Specifications (Con't).

Engine Specifications (Con't):	
Rated Horsepower.....	115 @ 2200 rpm
Fuel Types.....	No. 1 or No. 2 Grade Diesel Fuel
Transmission Specifications:	
Type.....	ZF of North America, Countershaft, Power Shift
Forward Speeds	Four
Reverse Speeds.....	Three
Torque Converter Type	Single Phase, Single Stage
System Pressure @ 150° ± ^{10°} and 1500 rpm	213-242 psi (1468-1669 kPa)
Drive Axle and Differentials Specifications:	
Type.....	John Deere, Inboard Planetary Axle with Standard Spiral Bevel Gear Differential
Differential Gear Reduction Ratio.....	4.333:1
Inboard Planetary Drive Reduction Ratio	4.800:1
Overall Axle Reduction Ratio.....	20.798:1
Service Brake Specifications:	
Type.....	Power Actuated, Wet Disc
Operation.....	Foot Pedal
Accumulators:	
Charging Medium.....	Dry Nitrogen
Charging Pressure	475-525 psi (3275-3620 kPa)
Parking Brake Specifications:	
Type.....	ZF of North America, Expanding Shoe
Operation.....	Manual, Foot Pedal
Mounting.....	Front of Transmission
Tire Specifications:	
Size.....	17.5-25
Type.....	Tubeless

1-10. EQUIPMENT DATA (Con't).

Table 1-1. General Characteristics and Specifications (Con't).

Tire Specifications (Con't):	
Ply Rating	16
Recommended Inflation Pressure	Rear: 40 psi (276 kPa) Front: 55 psi (379 kPa)
Hydraulic System Specifications:	
Steering Pump:	
Type	Commercial Steering, Gear, Constant Displacement
Rated Output	34 gpm @ 2000 psi
Forks/Brake Pump:	
Type	Sunstrand Piston, Variable Displacement, Pressure Compensated
Output (Minimum)	18.6 gpm @ 2000 psi
Steering System Relief Pressures:	
Priority Valve Relief Setting	2500 psi (17238 kPa)
Crossover Relief Valve Setting	2900 psi (19996 kPa)
Forks System Pressure Control Valve Setting	2750 psi (18961 kPa)

Section III. PRINCIPLES OF OPERATION

1-11. DRIVE TRAIN SYSTEM.

a. **Engine.** The engine is a six-cylinder turbocharged diesel which supplies rotational power to the transmission. The cooling system is pressurized and includes a thermostat, controlled bypass, and coolant recovery bottle. Engine lubrication is pressurized and oil is continuously cleaned by full-flow filters.

b. **Drive Dampener.** The drive dampener connects the engine to the transmission and absorbs torque spikes that could develop in the drive train.

c. **Transmission.** The transmission input shaft turns at engine speed. A speed reduction takes place within the transmission according to the speed range selected by the operator. The direction of forklift truck travel is also determined by the transmission. Both speed and direction selection are made by hydraulically operated clutches in the transmission.

d. **Drive Shafts.** The drive shafts transmit rotation of the transmission output to the front and rear axles. Connections at both ends are made through universal joints to compensate for any misalignment.

e. **Front and Rear Axles.** The front and rear axles are identical in operating principle. The rear axle is different in that it oscillates 11° above and below horizontal. Both axles drive whenever the transmission is engaged. Neither axle can be independently disconnected.

1-12. SERVICE BRAKE SYSTEM.

a. **Introduction.** The service brakes are foot controlled, hydraulic-type brakes. The system is supplied pressurized hydraulic oil by a pressure compensated pump that is driven by the engine.

b. **Brake and Forks Pump.** The brake and forks pump is a variable displacement, pressure compensated, piston-type pump. It supplies flow to both the service brake system and to the fork attachment cylinder circuits.

c. **Accumulators.** The accumulators in the brake system store a charge of pressurized oil which allows a number of brake applications in the event of pump failure or engine shutdown.

d. **Brake Valves.** The two brake valves are identical and are operated by separate foot pedals. Depressing either foot pedal will cause all four wheel brakes to operate.

e. **Wheel Brakes.** A wet disc-type brake arrangement is found at each wheel. When hydraulic pressure is routed to the brake pistons via the brake valves, the pistons move outward and compress the brake disc against the stationary backing plate, slowing or stopping the vehicle.

1-12. SERVICE BRAKE SYSTEM (Con't).

f. **Parking Brake.** The parking brake mechanism is mounted on the front of the transmission. The actuating pedal and release handle is located in the operator's cab. A red light flashes and an audible alarm sounds if the parking brake is applied while the engine is running and the transmission is In gear; a yellow light flashes if the parking brake is applied and the transmission is in N (Neutral).

1-13. STEERING SYSTEM.

a. **General.** The steering system is a full-time power assist-type. A secondary electrically operated pump is included to provide emergency steering. The other components of the system are the steering valve, cylinders, and crossover relief valve.

b. **Steering Hydraulic Pump.** The steering hydraulic pump supplies the steering system only. It is mounted on the back of the transmission and is driven by the engine. It is a fixed displacement, external gear-type pump.

c. **Secondary Steering Pump.** The secondary steering pump is electrically powered. It operates when the key switch is on and low steering system pressure is sensed by a pressure switch.

1-14. FORKLIFT HYDRAULIC SYSTEM.

a. **General.** The forklift hydraulic system includes the service brake system, steering system, hydraulic reservoir, and attachment components. The service brake and steering systems are described in paragraphs 1-12 and 1-13. The attachment components consist of the attachment control valve, oil cooler, and two oil filters.

b. **Hydraulic Reservoir.** The hydraulic reservoir is a 20 gl (76 l) tank, located just ahead of the engine.

c. **Attachment Control Valve.** The attachment control valve controls the operation of the forks for boom raise and lower, tilt, and spacing.

d. **Oil Cooler.** The oil cooler is mounted alongside the engine radiator and cools both the hydraulic system oil and the transmission oil in separate sections.

e. **Oil Filters.** There are two filters that are contained in the hydraulic system. The pump suction filter, located at the hydraulic reservoir, filters larger contaminants and uses a washable screen. The return filter combines a bypass valve and contains a replaceable cartridge-type filter. It filters contaminants entering the reservoir from the components of the system. Should the return filter become clogged, a warning indicator will light and the bypass valve will open.

1-15. ELECTRICAL SYSTEM.

a. **Charging System.** The 24-volt charging system consists of the batteries and an alternator with an internal regulator.

1-15. ELECTRICAL SYSTEM (Con't).

b. **Lighting System**. The lighting system is protected by a circuit breaker and contains two front service lights, an adjustable cab mounted worklight, two rear cab mounted worklights, front and rear turn signals, combination tail/brake lights, a cab domelight, front and rear blackout lights, and instrument panel lights.

c. **Monitoring System**. The monitoring system includes a variety of electrical senders, associated gages, and indicators located in the cab. This allows the operator to be aware of the status of the forklift truck during operation. For a description of the function of each monitor within the system, see Chapter 2, Section I.

d. **Window Wipers and Washers**. Separate wipers, washers, and controls are provided for the front and rear cab windows.

1-16. ON-BOARD CRANE.

The 900 lb (409 kg) capacity crane is used to remove and install the conveyORIZED forks, cab upper section, and counterweight. It is hand-operated and can be raised or lowered to three different operating positions with quick-release pins.

1-17. FORKLIFT WINTERIZATION PACKAGE.

a. The forklift truck is equipped with a winterization package that protects the truck down to -650F (-54°C).

b. The winterization package consists of a coolant heater, engine oil heater, and battery heaters. Heaters are operated by an exterior 110-volt AC power source and are equipped with a thermostat for overheat protection. An extension cord has been provided to connect the forklift truck to the power source.

c. The coolant heater is located in the engine cylinder head just behind the hydraulic reservoir.

d. The engine oil heater is located in the engine oil pan.

e. Each battery has a blanket-type heater wrapped around the battery case and a tray heater underneath it. The battery tray heaters are mounted on wooden insulators.

CHAPTER 2 OPERATING INSTRUCTIONS

Section I. DESCRIPTION AND USE OF OPERATOR'S CONTROLS AND INDICATORS

2-1. INTRODUCTION.

The information and illustrations in this chapter provide the basic instructions you will need to properly operate the M544E Forklift Truck. Before operating the vehicle, ensure that you know the location and operation of all controls and indicators. A thorough review of this section, and getting into the vehicle and identifying each control and indicator is the best way to do this.

2-2. CONTROLS AND INDICATORS.

The following illustrations and charts show the location and describe the function of the controls and indicators on this vehicle. Very often the lights and gages will indicate that something is wrong long before you realize it. Be familiar with them before you operate the vehicle.

2-2. CONTROLS AND INDICATORS (Con't).

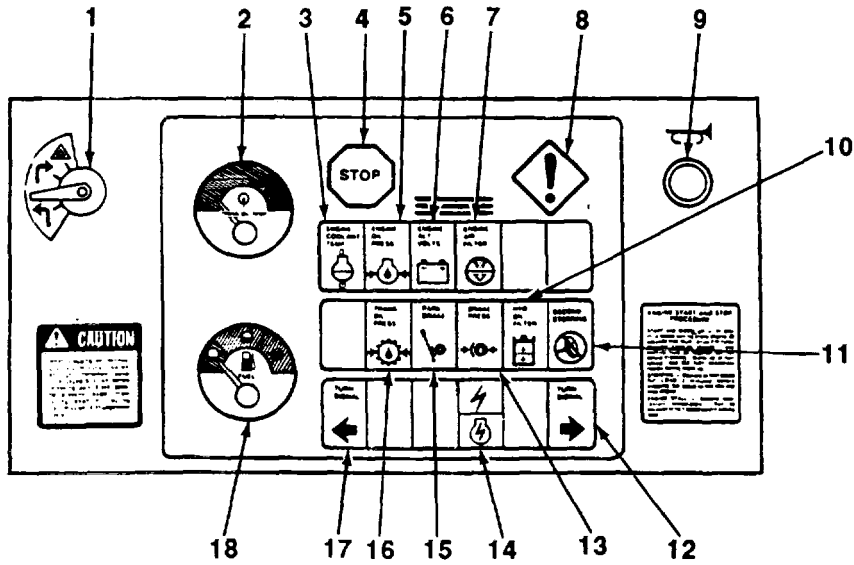

INSTRUMENT PANEL

KEY	CONTROL OR INDICATOR	FUNCTION
1	Turn Signal/Emergency Flashers Switch	Operates turn signals and emergency flashers.
2	Transmission Oil Temperature Gage	Shows transmission oil temperature. Green zone is normal operating range; red zone is high temperature range.
3	Engine Coolant High Temperature Indicator	Lights red if engine coolant temperature goes above 2240F (107°C).
4	Stop Engine Indicator	Lights red when engine oil pressure drops below safe operating range. An audible alarm will also sound.
5	Engine Oil Low Pressure Indicator	Lights when engine oil pressure drops below safe operating range. An audible alarm will also sound.
6	Battery Charging Indicator	Lights when alternator is not charging or batteries are low.

TA704473

2-2. CONTROLS AND INDICATORS (Con't).

KEY	CONTROL OR INDICATOR	FUNCTION
7	Engine Air Filter Restriction Indicator	Lights when engine air filter element requires servicing.
8	Caution - Service Required Indicator	Lights yellow when certain precautionary operating conditions occur.
9	Horn Button	Operates vehicle horn.
10	Hydraulic Filter Restriction Indicator	Lights when hydraulic filter element requires servicing.
11	Secondary Steering Warning Indicator	Lights when secondary steering pump motor is activated. An audible alarm will also sound.
12	Right Turn Signal Indicator	Flashes when turn signal switch is positioned for right-hand turn. Also flashes simultaneously with left turn signal indicator when emergency flashers are in use.
13	Brake Oil Low Pressure Indicator	Lights if hydraulic pressure in service brake system falls below the safe minimum level. An audible alarm will also sound.
14	Start Switch ON Indicator	Lights when start switch is in ON position and the engine is not running.
15	Parking Brake Indicator	Lights when parking brake is applied. An audible alarm will also sound.
16	Transmission Oil Low Pressure Indicator	Lights if transmission oil pressure drops below safe operating range.
17	Left Turn Signal Indicator	Flashes when turn signal switch is positioned for left-hand turn. Also flashes simultaneously with right turn signal indicator when emergency flashers are in use.
18	Fuel Gage	Indicates amount of fuel in vehicle's fuel tank.

2-2. CONTROLS AND INDICATORS (Con't).

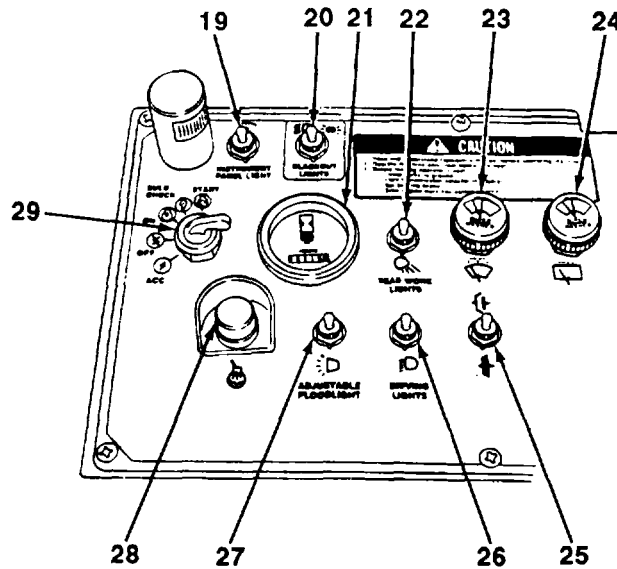

CONTROL PANEL

KEY	CONTROL OR INDICATOR	FUNCTION
19	Instrument Panel Light Switch	Operates instrument panel light.
20	Blackout Lights Switch	Operates blackout lights and markers.
21	Engine Hourmeter	Shows engine hours of operation.
22	Rear Worklight Switch	Operates two rear worklights.
23	Front Wiper/Washer Switch	Operates front windshield wiper and washer.
24	Rear Wiper/Washer Switch	Operates rear window wiper and washer.
25	Clutch Cut-off Switch	Operates transmission cut-off clutch and left brake pedal operation.
26	Driving Lights Switch	Operates vehicle driving lights.

TA704474

2-2. CONTROLS AND INDICATORS (Con't).

KEY	CONTROL OR INDICATOR	FUNCTION
27	Adjustable Floodlight Switch	Operates adjustable floodlight. Operates engine cold start aid. Operates cab accessories, Instrument panel BULB CHECK, ignition switch ON position, and engine start.
28	Starting Aid Switch	
29	Ignition Switch	

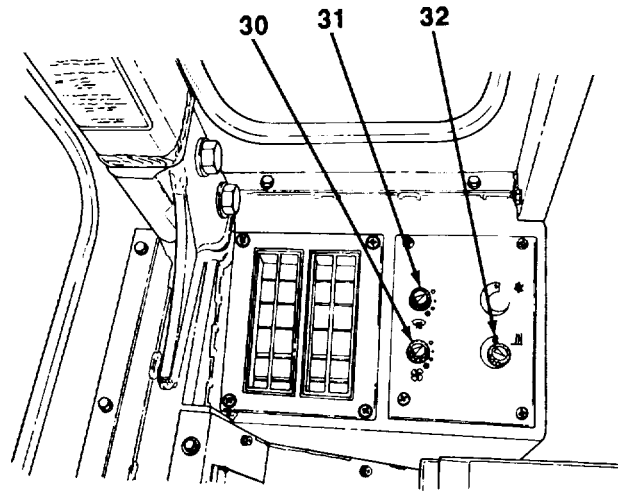

HEATER CONTROL PANEL

KEY	CONTROL OR INDICATOR	FUNCTION
30	Heater Blower Control	Operates heater blower motor. Operates defroster blower motor. Operates heater/defroster temperature range.
31	Defroster Blower Control	
32	Temperature Control	

TA704475

2-2. CONTROLS AND INDICATORS (Con't).

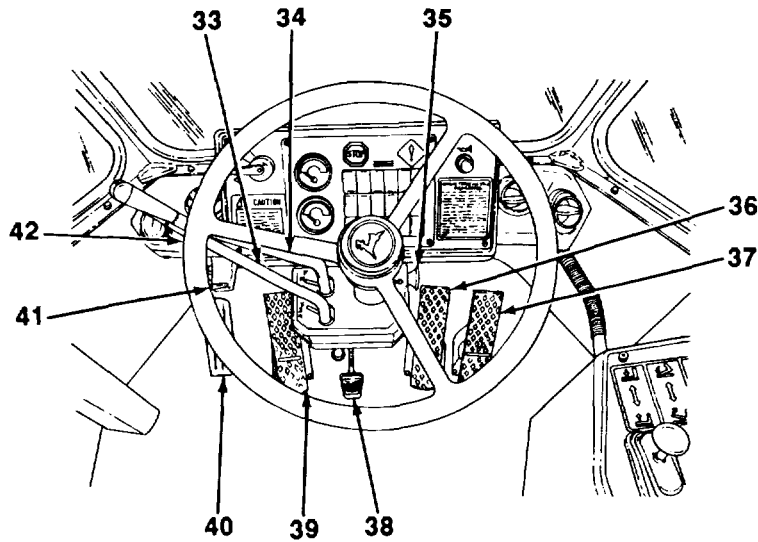

CAB CONTROLS

KEY	CONTROL OR INDICATOR	FUNCTION
33	Speed Range Selector Lever	Selects each of four forward speed ranges.
34	Direction Selector Lever	Selects N (Neutral), F (Forward), or R (Reverse). An audible alarm will also sound when vehicle is In R (Reverse).
35	Neutral Lock Button	Locks speed range selector lever and direction selector lever in N (Neutral).
36	Right Brake Pedal	Applies service brakes at all four wheels.
37	Accelerator Pedal	Controls engine rpm, thereby controlling vehicle speed within transmission speed range selected.
38	Steering Column Tilt Lock Release Pedal	Releases lock to tilt the steering column.
39	Left Brake Pedal	Applies service brakes at all four wheels. Also with clutch cut-off switch in OFF position, depressing the pedal will disconnect the transmission clutch.

TA704476

2-2. CONTROLS AND INDICATORS (Con't).

KEY	CONTROL OR INDICATOR	FUNCTION
40	Parking Brake Pedal	Applies forklift truck parking brake.
41	Parking Brake Release Lever	Releases forklift truck parking brake.
42	Steering Wheel	Steers vehicle.

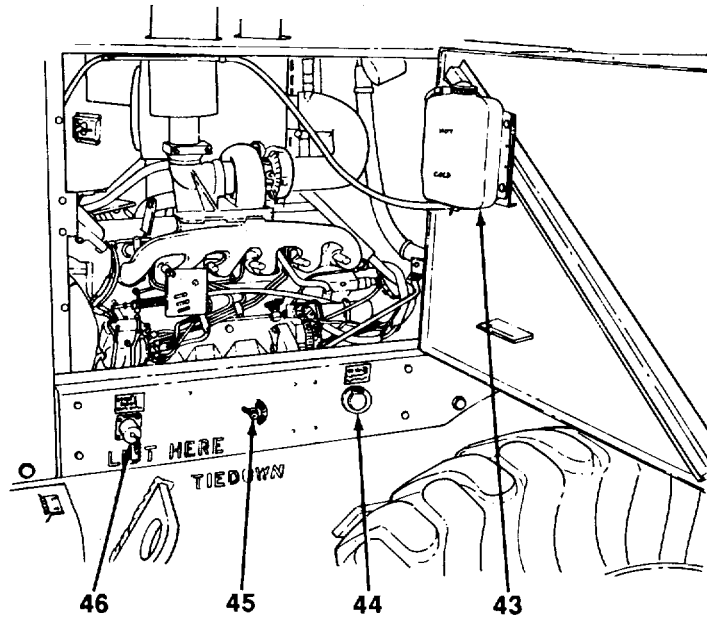

KEY	CONTROL OR INDICATOR	FUNCTION
43	Coolant Recovery Tank	Indicates the coolant level visually.
44	110-volt AC Receptacle	Connects 110-volt AC power source for vehicle winterization kit.
45	Battery Disconnect Switch	Disconnects batteries from vehicle electrical system.
46	Slave Receptacle	Accepts the slave starting cables to aid in slave starting the vehicle.

TA704477

2-2. CONTROLS AND INDICATORS (Con't).

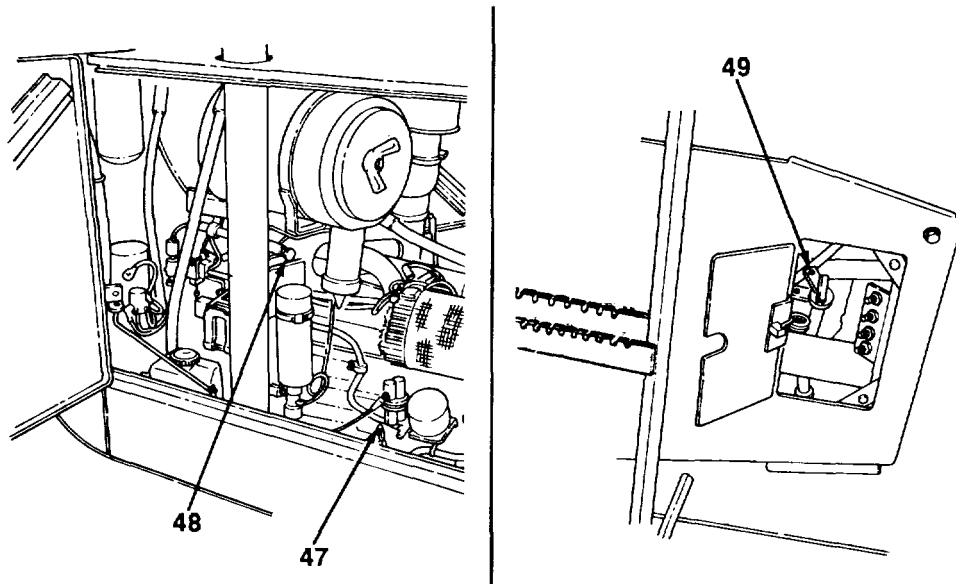

KEY	CONTROL OR INDICATOR	FUNCTION
47	Engine Oil Level Gage	Indicates engine oil level. Primes engine when hot. Used only when starting engine with JP-4 fuel.
48	Engine Primer Knob	
49	Transmission Oil Level Gage	Indicates transmission oil level.

TA704478

2-2. CONTROLS AND INDICATORS (Con't).

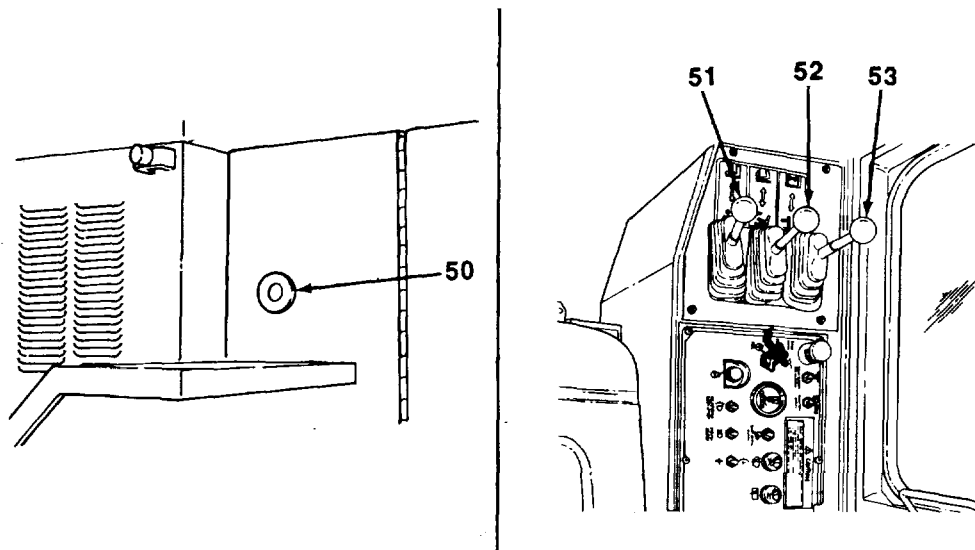

BOOM AND FORK CONTROLS

KEY	Control or Indicator	FUNCTION
50	Hydraulic Oil Level Sight Gage	Indicates the hydraulic oil level visually.
51	Fork Control Lever	Raises or lowers forks.
52	Fork Tilt Control Lever	Tilts forks forward or backward.
53	Fork Spacing Control Lever	Increases or decreases fork spacing.

TA704479

2-2. CONTROLS AND INDICATORS (Con't .

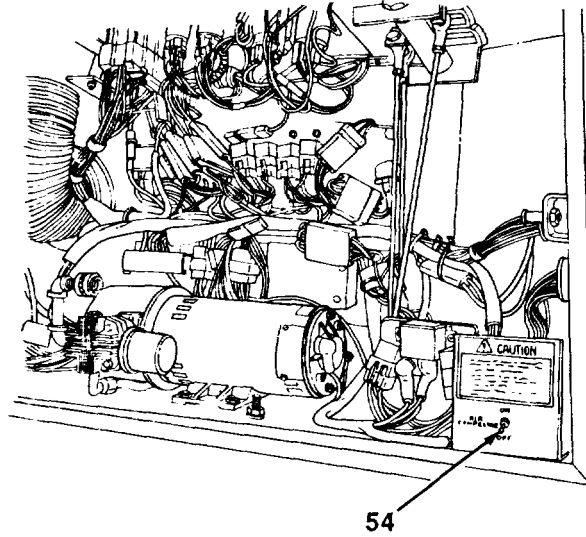

AIR COMPRESSOR CONTROL

KEY	Control or Indicator	FUNCTION
54	Air Compressor Switch	Turns air compressor on or off.

TA704480

Section II. PREVENTIVE MAINTENANCE CHECKS AND SERVICES (PMCS)

2-3. GENERAL.

Table 2-1 has been provided so that you can keep your equipment in good operating condition and ready for its primary mission.

2-4. WARNINGS AND CAUTIONS.

Always observe the WARNINGS and CAUTIONS appearing in your PMCS table. WARNINGS and CAUTIONS appear before applicable procedures. You must observe these WARNINGS and CAUTIONS to prevent serious injury to yourself and others or to prevent your equipment from being damaged.

2-5. EXPLANATION OF TABLE ENTRIES.

a. **Item Number Column.** Numbers in this column are for reference. When completing DA Form 2404 (*Equipment Inspection and Maintenance Worksheet*), include the item number for the check/service indicating a fault. Item numbers also appear in the order that you must perform checks and services for the Interval listed.

b. **Interval Column.** This column tells you when you must perform the procedure in the procedure column.

(1) *Before* procedures must be done before you operate or use the equipment for its intended mission.

(2) *During* procedures must be done during the time you are operating or using the equipment for its intended mission.

(3) *After* procedures must be done immediately after you have operated or used the equipment.

(4) *Weekly* procedures must be done once each week.

(5) *Monthly* procedures must be done once each month.

c. **Location, Check/Service Column.** This column provides the location and the item to be checked or serviced. The item location is underlined.

d. **Procedure Column.** This column gives the procedure you must perform to check or service the item listed in the Check/Service column to know if the equipment is ready or available for its intended mission or for operation. You must perform the procedure at the time stated in the Interval column.

2-5. EXPLANATION OF TABLE ENTRIES (Con't).

e. **Not Fully Mission Capable** If: Column. Information in this column tells you what faults will keep your equipment from being capable of performing its primary mission. If you make check and service procedures that show faults listed in this column, do not operate the equipment. Follow standard operating procedures for maintaining the equipment or reporting equipment failure.

2-6. OTHER TABLE ENTRIES.

Be sure to observe all special information and notes that appear in your table.

2-7. GENERAL PMCS PROCEDURES.

f. Always do your PMCS in the same order so it gets to be a habit. Once you've had some practice, you'll spot anything wrong in a hurry.

g. If anything looks wrong and you can't fix it, write it on your DA Form 2404. If you find something seriously wrong, IMMEDIATELY report it to Unit Maintenance.

h. When you perform PMCS, take along the tools you need to make all the checks. You'll always need a rag (Item 7, Appendix D) or two.

WARNING

Dry cleaning solvent, P-D-680, is toxic and flammable. Always wear protective goggles and gloves, and use only in a well-ventilated area. Avoid contact with skin, eyes, and clothes, and DO NOT breathe vapors. DO NOT use near open flame or excessive heat. The solvent's flash point is 1000F-138°F (380C-590C). If you become dizzy while using cleaning solvent, immediately get fresh air and medical help. If solvent contacts eyes, immediately wash your eyes and get medical aid.

- (1) **Keep It Clean.** Dirt, grease, oil, and debris get in the way and may cover up a serious problem. Clean as you work and as needed. Use dry cleaning solvent (Item 8, Appendix D) on all metal surfaces. Use soap (Item 2, Appendix D) and water when you clean rubber or plastic.
- (2) **Rust and Corrosion.** Check metal parts of vehicle and frame for rust and corrosion. If any bare metal or corrosion exists, clean and apply a light coat of oil. Report it to your supervisor.
- (3) **Bolts, Nuts, and Screws.** Check bolts, nuts, and screws for obvious looseness, missing, bent, or broken condition. You can't try them all with a tool, of course, but look for chipped paint, bare metal, or rust around bolt heads. If you find one you think is loose, tighten it or report it to Unit Maintenance if you can't tighten it.

2-7. GENERAL PMCS PROCEDURES (Con't).

- (4) **Welds.** Look for loose or chipped paint, rust, or gaps where parts are welded together. If you find a bad weld, report it to Unit Maintenance.
- (5) **Electric Wires and Connectors.** Look for cracked or broken insulation, bare wires, and loose or broken connectors. Tighten loose connectors and ensure that the wires are In good condition.
- (6) **Air and Hydraulic Hoses and Lines.** Look for wear, damage, and signs of leaks. Ensure that clamps and fittings are tight. Wet spots Indicate leaks, of course, but a stain around a fitting or connector can also mean a leak. If a leak comes from a loose fitting or connector, tighten it. If something is broken or worn out, report it to Unit Maintenance.
- (7) **Fluid Leakage.** It is necessary for you to know how fluid leakage affects the status of your forklift truck. The following are definitions of the types/classes of leakage you need to know to be able to determine the status of your forklift truck. Learn and be familiar with them, and remember - when in doubt, notify your supervisor!

Leakage Definitions for Operator/Crew PMCS

- Class I* Seepage of fluid (as indicated by wetness or discoloration) not great enough to form drops.
- Class II* Leakage of fluid great enough to form drops, but not enough to cause drops to drip from the item being Inspected.
- Class III* Leakage of fluid great enough to form drops that fall from the item being Inspected.

CAUTION

When operating with Class I or II leaks, continue to check fluid levels In addition to that required In PMCS. Parts without fluid will stop working or may be damaged.

- (a) Equipment operation is allowable with minor (Class I or II) leakage. Fluid levels in an item/system affected with such leakage must be checked more frequently than required in PMCS. When in doubt, notify your supervisor.
- (b) IMMEDIATELY report Class III leaks to Unit Maintenance.

Table 2-1. Preventive Maintenance Checks and Services.

ITEM NO.	INTERVAL	LOCATION ITEM TO CHECK/ SERVICE	PROCEDURE	NOT FULLY MISSION CAPABLE IF:
1	Before	<p>EXTER- IOR</p> <hr/> <p>Left Front and Side</p>	<p style="text-align: center;">WARNING</p> <p>Unless otherwise specified, perform all maintenance procedures with all equipment lowered to the ground, transmission locked in N (Neutral), parking brake applied, and engine stopped. Failure to perform these tasks may result in Injure or death to personnel.</p> <p style="text-align: center;">CAUTION</p> <p>New vehicle break-in maintenance is required on the forklift truck at 80-100 hours. Contact Unit Maintenance to avoid damaging the vehicle.</p> <p style="text-align: center;">NOTE</p> <ul style="list-style-type: none"> • Always remember to review all WARNINGS, CAUTIONS, and NOTES before operating the forklift truck and prior to performing PMCS. • Perform all PMCS checks if: <ul style="list-style-type: none"> a. You are the assigned driver but have not operated the vehicle since the last <i>Weekly</i> Inspection. b. You are operating the vehicle for the first time. <p style="text-align: center;">NOTE</p> <p>If leakage is detected, further investigation is needed to determine the location and cause of the leak.</p> <ul style="list-style-type: none"> a. Check underneath vehicle for evidence of fluid leakage. 	<p>a. Class III leak of oil or coolant. Class II leak of fuel.</p>

Table 2-1. Preventive Maintenance Checks and Services (Con't).

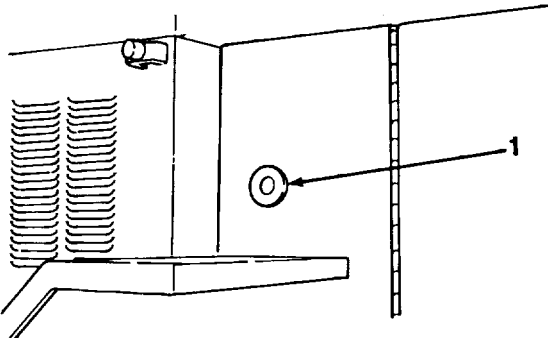
ITEM NO.	INTERVAL	LOCATION ITEM TO CHECK/ SERVICE	PROCEDURE	NOT FULLY MISSION CAPABLE IF:
1 (Con't)	Before	Left Front and Side	b. Check left side of vehicle for obvious damage that would impair operation.	b. Any damage that will prevent operation.
2	Before	Left Side Tires	<p style="text-align: center;">WARNING</p> <p>Operating a vehicle with an underinflated tire or with a questionable tire defect may lead to premature tire failure and may result in equipment damage, or injury or death to personnel.</p> <p>Visually check tire for presence and underinflation.</p>	Tire is missing, deflated, or unserviceable.
3	Before	Hydraulic System Reservoir	<p style="text-align: center;">NOTE</p> <p>The vehicle must be parked on level ground with fork carriage lowered to ground.</p> <p>Visually check oil level in hydraulic reservoir (see paragraph 3-10). Oil level should be in center of hydraulic oil level sight gage (1). Add sufficient fluid to bring oil level to center of hydraulic oil level sight gage.</p> 	

A704481

Table 2-1. Preventive Maintenance Checks and Services (Con't).

ITEM NO.	INTERVAL	LOCATION ITEM TO CHECK/ SERVICE	PROCEDURE	NOT FULLY MISSION CAPABLE IF:
4	Before	Air Cleaner Dust Valve	<p style="text-align: center;">WARNING</p> <p>If NBC exposure is suspected, all engine air cleaner air filter media should be handled by personnel wearing protective equipment. Consult your NBC Officer or NBC NCO for appropriate handling or disposal procedures.</p> <p>Squeeze dust valve (2) to remove dust from air cleaner.</p> 	

Table 2-1. Preventive Maintenance Checks and Services (Con't).

ITEM NO.	INTERVAL	LOCATION ITEM TO CHECK/ SERVICE	PROCEDURE	NOT FULLY MISSION CAPABLE IF:
5	Before	Engine Oil Level	<p style="text-align: center;">CAUTION</p> <ul style="list-style-type: none"> • DO NOT overfill engine crankcase. Damage to engine will result. • DO NOT permit dirt, dust, or grit to enter engine oil level gage tube. Internal engine damage will result if engine oil is contaminated. <p>Check engine oil level (3) (see paragraph 3-6). Level should be between ADD and FULL. If level is below ADD, add oil to bring level between ADD and FULL marks.</p>	

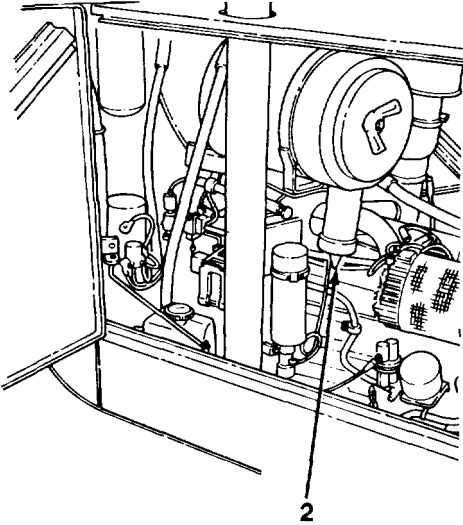
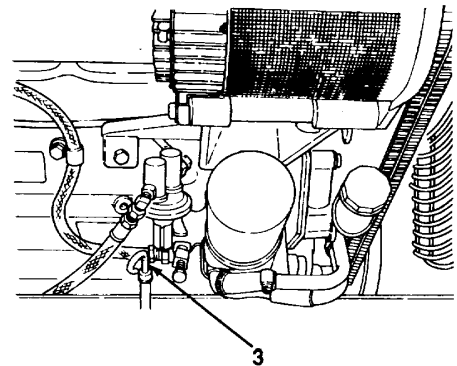

TA704483

Table 2-1. Preventive Maintenance Checks and Services (Con't).

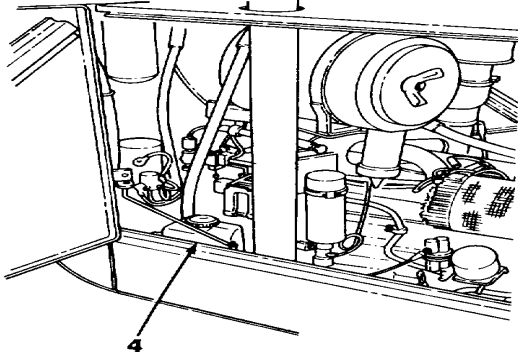
ITEM NO.	INTERVAL	LOCATION	PROCEDURE	NOT FULLY MISSION CAPABLE IF:
		ITEM TO CHECK/SERVICE		
6	Before	Windshield Washer Fluid	<p>Check fluid in windshield washer bottle (4) (see paragraph 3-9). Add fluid as required.</p> 	
7	Before	Fan and Alternator Belts	<p>Check for loose, missing, broken, cracked, or frayed drive belts.</p>	
8	Before	Rear	<p>NOTE If leakage is detected, further investigation is needed to determine the location and cause of the leak.</p> <ol style="list-style-type: none"> a. Check underneath vehicle for evidence of fluid leakage. b. Check rear of vehicle for obvious damage that would impair operation. 	<ol style="list-style-type: none"> a. Class III leak of oil or coolant. Class II leak of fuel. b. Any damage that will prevent operation.

TA704484

Table 2-1. Preventive Maintenance Checks and Services (Con't).

ITEM NO.	INTERVAL	LOCATION ITEM TO CHECK/ SERVICE	PROCEDURE	NOT FULLY MISSION CAPABLE IF:
9	Before	Cooling System	<p style="text-align: center;">WARNING</p> <p>DO NOT remove radiator fill cap unless engine is cold. This is a pressurized cooling system and escaping steam, hot water, or coolant will cause serious burns.</p> <p style="text-align: center;">NOTE</p> <p>DO NOT remove radiator fill cap to perform this check.</p> <ol style="list-style-type: none"> a. Visually check coolant level in coolant recovery tank (5) from top of vehicle (see paragraph 3-8). Level should be at or above COLD line. Add fluid if level is below COLD line. b. Visually check radiator for leaks, damage, or obstructions. Remove any obstructions. 	<p>b. Class III leak of coolant.</p>

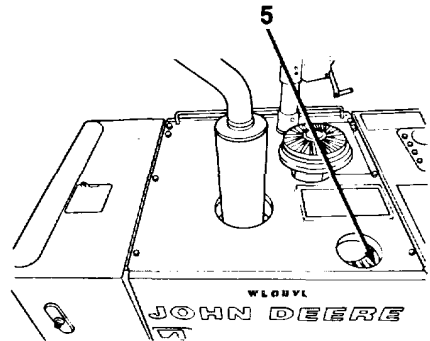

TA704485

Table 2-1. Preventive Maintenance Checks and Services (Con't).

ITEM NO.	INTERVAL	LOCATION	PROCEDURE	NOT FULLY MISSION CAPABLE IF:
		ITEM TO CHECK/SERVICE		
10	Before	Right Side Tires	<p>WARNING</p> <p>Operating a vehicle with an underinflated tire or with a questionable tire defect may lead to premature tire failure and may result in equipment damage, or injury or death to personnel.</p> <p>Visually check tires for presence and underinflation.</p>	Tire is missing, deflated, or unserviceable.
11	Before	Right Front and Side	<p>NOTE</p> <p>If leakage is detected, further investigation is needed to determine the location and cause of the leak.</p> <ul style="list-style-type: none"> a. Check underneath vehicle for evidence of fluid leakage. b. Check right side of vehicle for obvious damage that would impair operation. 	<ul style="list-style-type: none"> a. Class III leak of oil or coolant. Class II leak of fuel. b. Any damage that will prevent operation.
12	Before	Front Exterior	<p>NOTE</p> <p>If leakage is detected, further investigation is needed to determine the location and cause of the leak.</p> <ul style="list-style-type: none"> a. Check underneath vehicle for evidence of fluid leakage. b. Check front of vehicle for obvious damage that would impair operation. 	<ul style="list-style-type: none"> a. Class III leak of oil or coolant. Class II leak of fuel. b. Any damage that will prevent operation.

Table 2-1. Preventive Maintenance Checks and Services (Con't).

ITEM NO.	INTERVAL	LOCATION	PROCEDURE	NOT FULLY MISSION CAPABLE IF:
		ITEM TO CHECK/SERVICE		
13	Before	INTER- IOR Seatbelts and Seat	<p style="text-align: center;">NOTE</p> <p>Vehicle operation with Inoperative seatbelts may violate AR 385-55.</p> <p>a. Check seatbelt for security, damage, and completeness.</p> <p>b. Check operation of seat release lever (see paragraph 2-9).</p>	b. Seat release lock is broken or missing.
14	Before	Fire Extinguisher	<p>a. Check for missing or damaged fire extinguisher.</p> <p>b. Check pressure gage for proper pressure of about 150 psi (1034 kPa).</p> <p>c. Check for damaged or missing seal.</p>	

Table 2-1. Preventive Maintenance Checks and Services (Con't).

ITEM NO.	INTERVAL	LOCATION	PROCEDURE	NOT FULLY MISSION CAPABLE IF:
		ITEM TO CHECK/SERVICE		
15	Before	Transmission Controls	<p>a. With parking brake set and neutral lock button (8) pulled out, check direction selector lever (7) and speed range selector lever (6). Levers should move freely through all ranges.</p> 	<p>a. Levers are inoperable or bind between ranges.</p>
16	Before	Instrument Panel (Prestart Check)	<p>WARNING If gages, instruments, or instrument lights are not operating as described in the following checks, IMMEDIATELY shut off Ignition and notify supervisor or Unit Maintenance. Continued operation of vehicle may result in Injury to personnel or damage to equipment.</p> <p>a. Visually check instrument panel for broken or unserviceable gages.</p>	<p>a. Any temperature or pressure gage is unreadable.</p>

Table 2-1. Preventive Maintenance Checks and Services (Con't).

ITEM NO.	INTERVAL	LOCATION	PROCEDURE	NOT FULLY MISSION CAPABLE IF:
		ITEM TO CHECK/SERVICE		
16 (Con't)	Before	Instru- ment Panel (Prestart Check)	b. Place ignition switch on control panel in ON position. Fuel gage must indicate fuel level. If fuel gage is inoperative notify Unit Maintenance and fill fuel tank prior to use. c. Place ignition switch on control panel in BULB CHECK position. All monitor lights must come on. Stop engine indicator light must flash and monitor alarm must sound.	c. Monitor lights, monitor alarm, or stop engine light are inoperative.
17	Before	Lights	<p style="text-align: center;">NOTE</p> <p>Vehicle operation with damaged or Inoperable headlights may violate AR 385-55.</p> Check for presence and operation of service, turn signal, tail/brake, work, blackout marker, and blackout drive lights.	
18	Before	Horn	<p style="text-align: center;">NOTE</p> <p>Operation of vehicle with Inoperative horn may violate AR 385-55.</p> Check operation of horn if tactical situation permits.	
19	Before	Windshield and Wipers	<p style="text-align: center;">NOTE</p> <p>Operation of vehicles with damaged windshield may violate AR 385-55.</p> a. Check windshield for damage that would impair operator's vision.	a. Windshield has damage impairing operator's vision.

Table 2-1. Preventive Maintenance Checks and Services (Con't).

ITEM NO.	INTERVAL	LOCATION	PROCEDURE	NOT FULLY MISSION CAPABLE IF:
		ITEM TO CHECK/SERVICE		
19 (Con't)	Before	Windshield and Wipers	<p style="text-align: center;">NOTE</p> <p>Vehicle operation with Inoperative wipers may violate AR 385-55.</p> <p>b. Check windshield wiper and rear window wiper blades for presence and damage.</p>	
20	Before	Mirror	<p style="text-align: center;">NOTE</p> <p>Vehicle operation with damaged or missing rearview mirror may violate AR 385-55.</p> <p>Check for presence, cracks, and serviceability of mirror.</p>	
21	Before	Engine Startup	<p>a. Start engine (see paragraph 2-11). Monitor stop engine indicator light. Light should go out approximately 10 seconds after engine starts. If light does not go out within 10 seconds, immediately shut down engine and notify Unit Maintenance.</p> <p>b. Monitor all other gages and warning lights.</p>	<p>a. Engine stop indicator light does not go out after 10 seconds.</p> <p>b. Engine oil low pressure, engine coolant high temperature, brake oil low pressure, or secondary steering warning indicator lights are on. Transmission oil temperature gage is in red zone.</p>

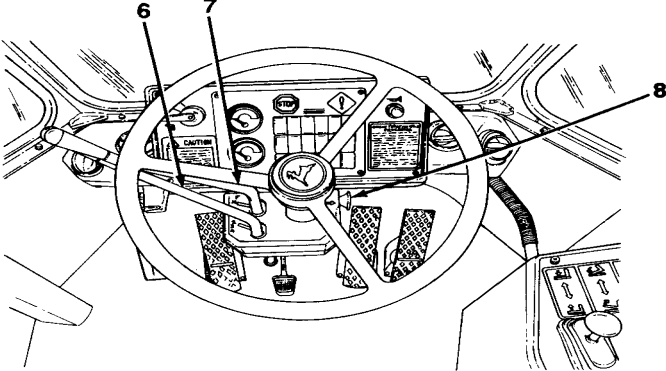
Table 2-1. Preventive Maintenance Checks and Services (Con't).

ITEM NO.	INTERVAL	LOCATION ITEM TO CHECK/ SERVICE	PROCEDURE	NOT FULLY MISSION CAPABLE IF:
22	Before	Backup Alarm	With ignition switch in Start position, place direction selector lever in R (Reverse). Backup alarm should sound.	Backup alarm inoperative.
23	Before	Brake Accumulators	a. Check brake accumulators by starting the engine, and running engine for one minute at half throttle. Operate brake pedal four or five times. Stop engine. b. Turn ignition switch to BULB CHECK position, then to ON position. c. Depress brake pedal. Brake oil low pressure indicator must light between four and 12 full brake pedal applications.	c. The brake oil low pressure indicator light does not light.
24	Before	Secondary Steering System	a. Check secondary system by parking vehicle on level ground with engine off and brakes released. b. Momentarily turn ignition switch to START position, but DO NOT start engine. Release ignition switch to ON position. Secondary steering warning indicator light should light and audible alarm should sound.	b. The secondary steering warning indicator does not light or alarm does not sound.

Table 2-1. Preventive Maintenance Checks and Services (Con't).

ITEM NO.	INTERVAL	LOCATION	PROCEDURE	NOT FULLY MISSION CAPABLE IF:
		ITEM TO CHECK/SERVICE		
25	Before	Parking Brake	<p>a. Check vehicle parking brake by applying parking brake and moving direction selector lever to F (Forward) and speed range selector lever to fourth gear. Engine stop and parking brake indicators should light and alarm should sound.</p> <p>CAUTION Perform this check in the absolute minimum time required to obtain safe results. Damage to the drive train will result if duration of check is excessive.</p> <p>b. With engine running, direction selector lever set to F (Forward), and speed range selector lever in fourth gear, gradually increase engine speed to half throttle momentarily. Decrease engine speed to normal idle. Move direction selector lever to N (Neutral).</p>	<p>a. Indicator lights do not come on or alarm does not sound.</p> <p>b. Parking brake does not hold vehicle.</p>
26	Before	<p>EXTERIOR</p> <p>Transmission Oil Level</p>	<p>CAUTION</p> <ul style="list-style-type: none"> • DO NOT overfill transmission. Damage to transmission will result. • DO NOT permit dirt, dust, or grit to enter transmission oil level gage tube. Internal transmission damage will result if transmission oil is contaminated. 	

Table 2-1. Preventive Maintenance Checks and Services (Con't).

ITEM NO.	INTERVAL	LOCATION ITEM TO CHECK/ SERVICE	PROCEDURE	NOT FULLY MISSION CAPABLE IF:
26 (Con't)	Before	Transmission Oil Level	<p style="text-align: center;">NOTE</p> <p>Transmission fluid level should be checked with the engine running, parking brake set, direction selector lever in N (Neutral) with neutral lock button engaged, and vehicle on level ground. Fluid level should show between ADD and FULL on transmission oil level gage.</p> <p>Check transmission fluid level (9) (see paragraph 3-7). If level is below ADD, add sufficient fluid to bring level between ADD and FULL marks. After completing transmission fluid level check, turn off engine.</p> 	TA704487

Table 2-1. Preventive Maintenance Checks and Services (Con't).

ITEM NO.	INTERVAL	LOCATION	PROCEDURE	NOT FULLY MISSION CAPABLE IF:
		ITEM TO CHECK/ SERVICE		
27	During	INTERIOR Controls and Indicators	Monitor all gages and warning lights.	Warning lights are on or gages drop below normal reading.
28	During	Brakes	a. Check brakes for pulling or grabbing. b. While operating service brake pedal, check to ensure that pedal is firm and does not completely depress to floor.	a. Brakes pull or grab. b. Pedal is spongy or goes completely to floor.
29	During	Steering	Operate steering wheel, checking for proper and smooth operation of steering.	Steering is erratic or noisy.
30	During	Power Train	Be alert for unusual noises or vibration from transmission, differentials, propeller shafts, axle shafts, or wheels.	Unusual noise or vibrations exist.
31	During	Fork Carriage	a. Check fork carriage tilt movement forward and backward. Check for smooth operation. b. Check fork carriage movement right and left. Check for smooth operation.	a. Fork carriage tilt is erratic or inoperative. b. Movement of fork carriage is erratic or inoperative.
32	After	EXTERIOR Rear	<p style="text-align: center;">NOTE</p> <p>If leakage is detected, further investigation is needed to determine the location and cause of the leak.</p> <p>a. Check underneath vehicle for evidence of fluid leakage.</p>	a. Class III leak of oil or coolant. Class II leak of fuel.

Table 2-1. Preventive Maintenance Checks and Services (Con't).

ITEM NO.	INTERVAL	LOCATION ITEM TO CHECK/ SERVICE	PROCEDURE	NOT FULLY MISSION CAPABLE IF:
32 (Con't)	After	Rear	b. Check rear of vehicle for obvious damage that would impair operation.	b. Any damage that will prevent operation.
33	After	Right Side Rear	Ensure that battery disconnect switch (10) is set to OFF position.	
34	After	Right Side Tires	 <p style="text-align: center;">WARNING Operating a vehicle with an underinflated tire or with a questionable tire defect may lead to premature tire failure and may result in equipment damage, or injury or death to personnel.</p> <p>Visually check tires for presence, underinflation, and serviceability.</p>	

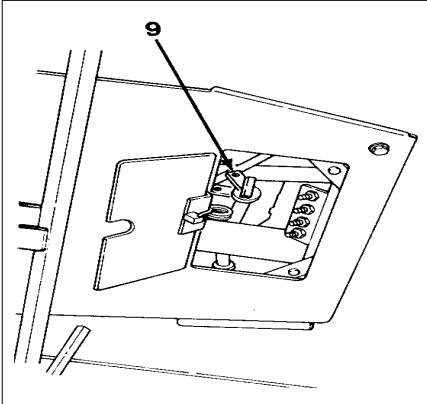
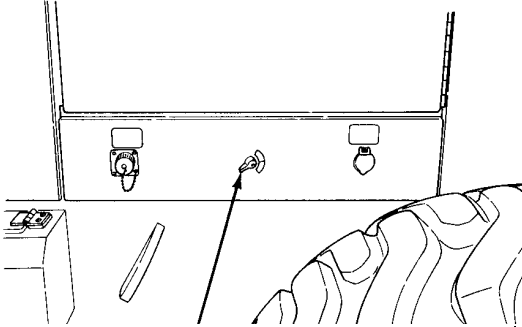
TA704488

Table 2-1. Preventive Maintenance Checks and Services (Con't).

ITEM NO.	INTERVAL	LOCATION ITEM TO CHECK/ SERVICE	PROCEDURE	NOT FULLY MISSION CAPABLE IF:
35	After	Right Front and Side	<p style="text-align: center;">NOTE</p> <p>If leakage is detected, further investigation is needed to determine the location and cause of the leak.</p> <p>a. Check underneath vehicle for evidence of fluid leakage.</p> <p>b. Check right side of vehicle for obvious damage that would impair operation.</p>	<p>a. Class III leak of oil or coolant. Class II leak of fuel.</p> <p>b. Any damage that will prevent operation.</p>
36	After	Front	<p style="text-align: center;">NOTE</p> <p>If leakage is detected, further Investigation is needed to determine the location and cause of the leak.</p> <p>a. Check underneath vehicle for evidence of fluid leakage.</p> <p>b. Check front of vehicle for obvious damage that would impair operation.</p>	<p>a. Class III leak of oil or coolant. Class II leak of fuel.</p> <p>b. Any damage that will prevent operation.</p>
37	After	Left Front and Side	<p style="text-align: center;">NOTE</p> <p>If leakage is detected, further investigation is needed to determine the location and cause of the leak.</p> <p>a. Check underneath vehicle for evidence of fluid leakage.</p>	<p>a. Class III leak of oil or coolant. Class II leak of fuel.</p>

Table 2-1. Preventive Maintenance Checks and Services (Con't).

ITEM NO.	INTERVAL	LOCATION ITEM TO CHECK/ SERVICE	PROCEDURE	NOT FULLY MISSION CAPABLE IF:
37 (Con't)	After	Left Front and Side	b. Check left side of vehicle for obvious damage that would impair operation.	b. Any damage that will prevent operation.
38	After	Left Side Tires	<p style="text-align: center;">WARNING</p> <p>Operating a vehicle with an underinflated tire or with a questionable tire defect may lead to premature tire failure and may result in equipment damage, or injury or death to personnel.</p>	
39	Weekly	EXTERIOR Boom Frame	<p>Visually check tire for presence, underinflation, and serviceability.</p> <p style="text-align: center;">WARNING</p> <p>While operating boom frame, extreme care must be taken to ensure that boom frame does not come near overhead wires. Contacting electrical power cables may result in serious injury or death to personnel.</p> <p>Operate boom frame, raise, and lower. Check for smooth operation.</p>	<p>Tire is missing, deflated, or unserviceable.</p> <p>Boom frame is erratic or does not function properly.</p>

Table 2-1. Preventive Maintenance Checks and Services (Con't).

ITEM NO.	INTERVAL	LOCATION	PROCEDURE	NOT FULLY MISSION CAPABLE IF:
		ITEM TO CHECK/SERVICE		
40	Weekly	Batteries	<p>WARNING</p> <ul style="list-style-type: none"> Remove all Jewelry such as rings, dog tags, bracelets, etc. If jewelry contacts battery terminal, a direct short will result, causing Instant heating of Jewelry which will result in severe Injury to personnel. DO NOT perform battery system checks or inspections while smoking or near fire, flames, or sparks. Batteries may explode, causing serous Injury or death to personnel. <p>Visually check batteries for defects such as burned or corroded terminals, or a cracked or damaged case.</p>	<p>One or more batteries are missing or unserviceable. Any loose terminal or cable. Any battery hold-down not secure.</p> <p>a. Any evidence of damage to air cleaner cover, body, or mounting that will allow unfiltered air to enter engine.</p>
41	Weekly	Air Cleaner	<p>WARNING</p> <p>If NBC exposure is suspected, all engine air cleaner air filter media should be handled by personnel wearing protective equipment. Consult your NBC Officer or NBC NCO for appropriate handling or disposal procedures.</p> <p>a. Visually check air cleaner cover and air cleaner assembly for security of mounting and damage.</p> <p>b. Remove air cleaner primary filter element (see paragraph 3-11).</p>	

Table 2-1. Preventive Maintenance Checks and Services (Con't).

ITEM NO.	INTERVAL	LOCATION	PROCEDURE	NOT FULLY MISSION CAPABLE IF:
		ITEM TO CHECK/SERVICE		
41 (Con't)	Weekly	Air Cleaner	<p>WARNING Compressed air used for cleaning or drying purposes, or for clearing restrictions, should never exceed 30 psi (207 kPa). Wear protective clothing (goggles/shield, gloves, etc.) and use caution to avoid Injury to personnel.</p> <p>(1) Clean dusty filter element with compressed air.</p> <p>(2) Clean oily or sooty filter element with warm water and detergent (Item 2, Appendix D).</p>	

Section III. OPERATION UNDER USUAL CONDITIONS

2-8. OPERATE DOOR AND WINDOW.

a. Operate Cab Door.

- (1) Push In button (1) on exterior door handle
- (2) to release door (3).
- (2) Pull open door (3).

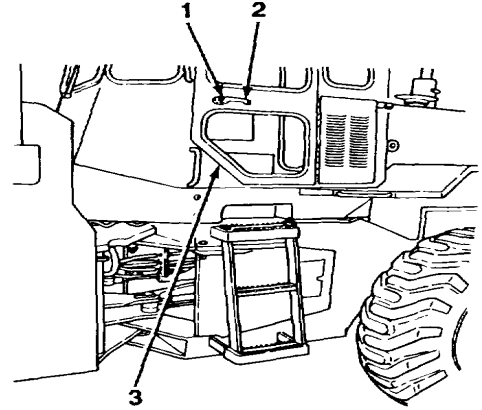

- (3) If door (3) is to remain open, it must be completely opened and latched.

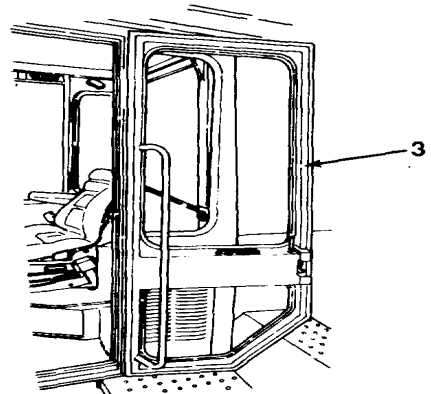

TA704489

2-8. OPERATE DOOR AND WINDOW (Con't).

- (4) To release latched door (3), pull forward on door release lever (4) at top left rear of cab.
- (5) To open closed door (3) from inside cab, push out on door latch (5).

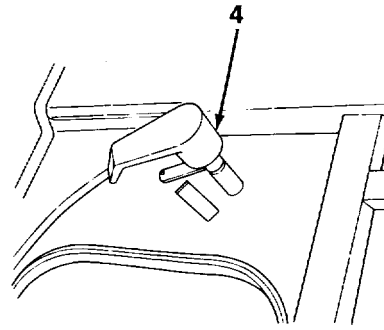

b. Operate Right Side Cab Window.

- (1) Pull latch handle (7) rearward and push out on latch handle.
- (2) To latch window (6) slightly open, latch second notch (10) on latch handle to latch bracket (9).

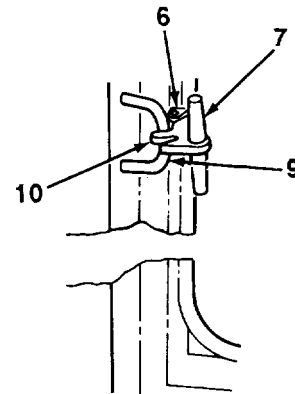
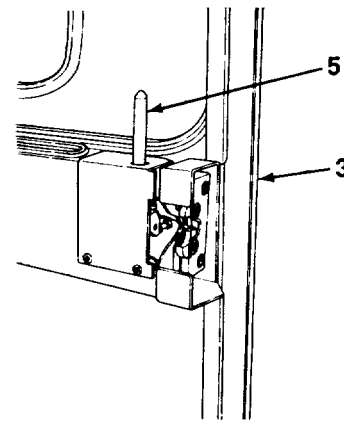

TA704490

2-8. OPERATE DOOR AND WINDOW (Con't).

- (3) To latch window (6) open in intermediate position, engage latch rod (11) in catch (13) in window frame (12).

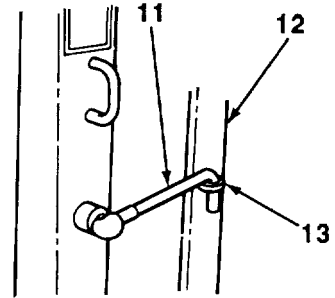

- (4) To latch window (6) fully open, push window until window latches at rear of cab.
- (5) To release latched window (6), pull forward on window release lever (14) at top right rear of cab.
- (6) To latch window (6) fully closed, engage first notch (8) on latch handle (7) to latch bracket (9) and place latch rod (11) in stowage position.

TA704491

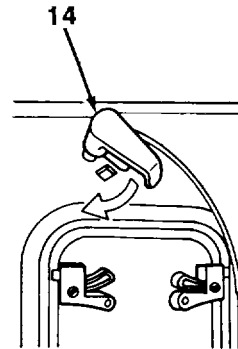
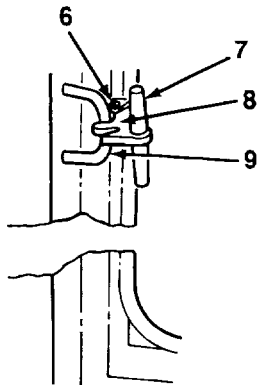

TA704491

2-9. OPERATE DRIVER'S SEAT.

NOTE

Make only those seat adjustments as necessary for comfort.

- a. Tilt of operator's seat (1) can be adjusted by turning seat tilt adjustment knob (2) clockwise to lower cushion (3) and counterclockwise to raise cushion.

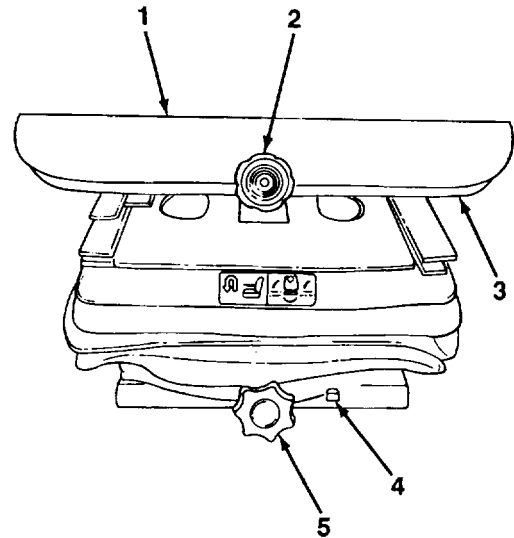
**NOTE**

- Seat springs can be adjusted to compensate for operator weights ranging from 110-280 lb (50-127 kg).
- Weight indicator window is calibrated in kilograms.

- b. Weight compensation of operator's seat (1) can be adjusted by turning weight adjustment knob (5) clockwise to increase weight compensation and counterclockwise to decrease weight compensation. Weight adjustment will be displayed in weight indicator window (4).

- c. Backrest cushion adjustment.

- (1) Turn lumbar depth adjustment knob (10) counterclockwise to move backrest cushion (11) against operator's back and clockwise to move backrest cushion away from operator's back.

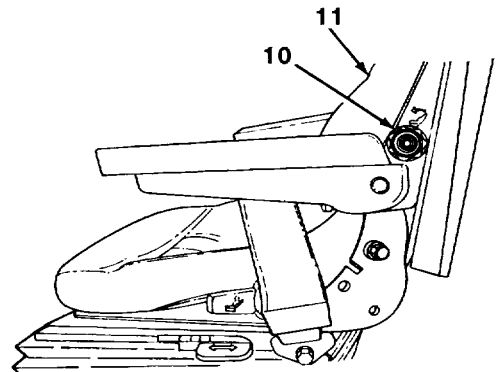

TA704492

TA704492

2-9. OPERATE DRIVER'S SEAT (Con't)

- (2) Turn lumbar curvature and vertical adjustment knob (13) counterclockwise to lower lumbar support and clockwise to raise lumbar support.
- (3) Adjust backrest cushion (11) tilt by lifting backrest cushion tilt adjustment release lever (7) and moving backrest cushion to desired angle.

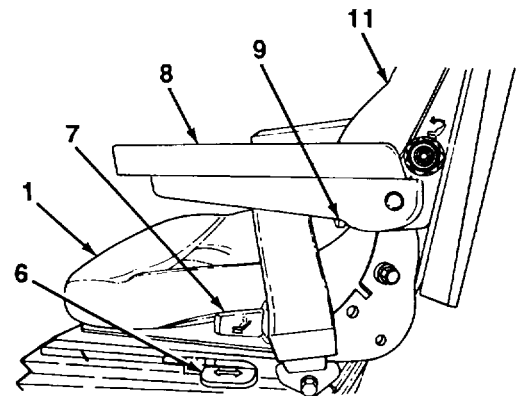
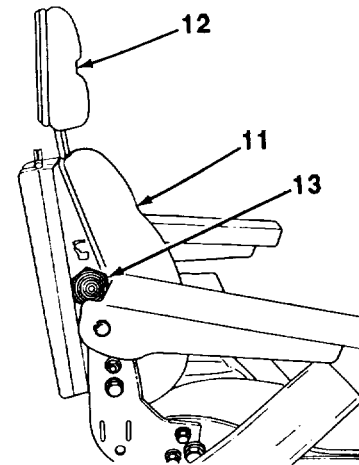

TA704493

- (4) Adjust backrest extension (12) height by pulling up or pushing down on backrest extension.

d. Armrest (8) adjustment.

- (1) Adjust tilt by turning armrest tilt adjustment knob (9) clockwise to increase tilt of armrest (8) and counterclockwise to decrease tilt of armrest.
- (2) Height of armrest (8) can also be adjusted. If adjustment is required, notify Unit Maintenance.

TA704493

2-9. OPERATE DRIVER'S SEAT (Con't).

e. Operator's seat (1) can be moved forward or rearward by lifting on seat release lever (6) and sliding operator's seat in desired direction. Ensure that operator's seat locks in position.

f. Operator's seat (1) can be moved up or down to one of three positions by lifting up on operator's seat. When operator's seat is raised past third (top) position, it returns to lowest position; it cannot be lowered incrementally.

2-10. OPERATE DRIVER'S SEATBELT.

- a. Adjust driver's seat (see paragraph 2-9).
- b. Press seatbelt release button (5) and pull out seatbelt (2) to desired length.
- c. Push metal end (3) of seatbelt (2) into seatbelt buckle (1).
- d. To release seatbelt (2), press release button on seatbelt buckle (1) and allow seatbelt to be reeled onto seatbelt reel (4).

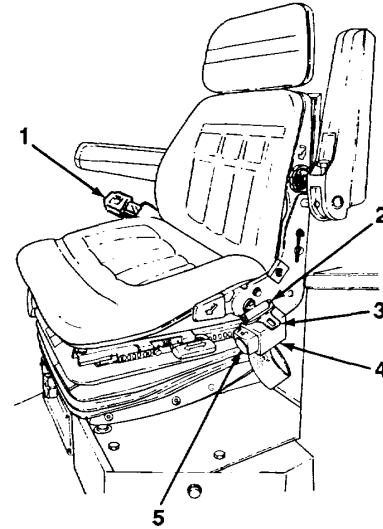

TA704494

2-11. START ENGINE.

- a. Turn battery disconnect switch (1) to ON position.

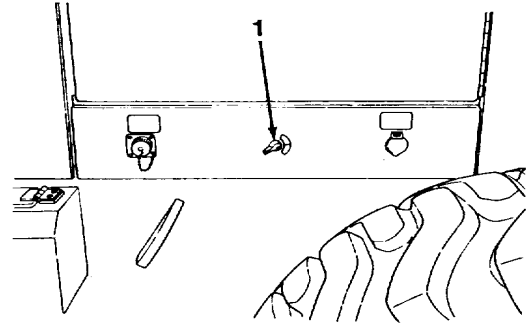

- b. Turn Ignition switch (2) to ON position.

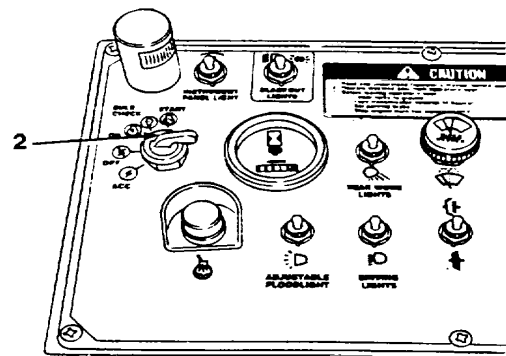

TA704495

WARNING

Start engine only while properly seated on operator's seat, seatbelt fastened, cab door and cab right side window latched in desired position, and mirror adjusted. Failure to follow this warning may result in injury or death to operator or nearby personnel.

- c. Sound horn (5) to alert personnel in area that forklift truck is being started.
- d. Move Ignition switch (2) to BULB CHECK position and ensure that all indicators light.

TA704495

2-11. START ENGINE (Con't).

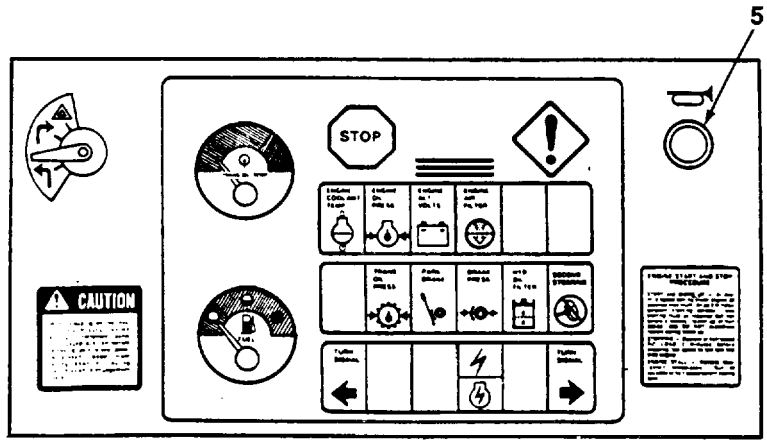

e. Ensure that direction selector lever (6) is in N (Neutral) and neutral lock button (7) is pushed in.

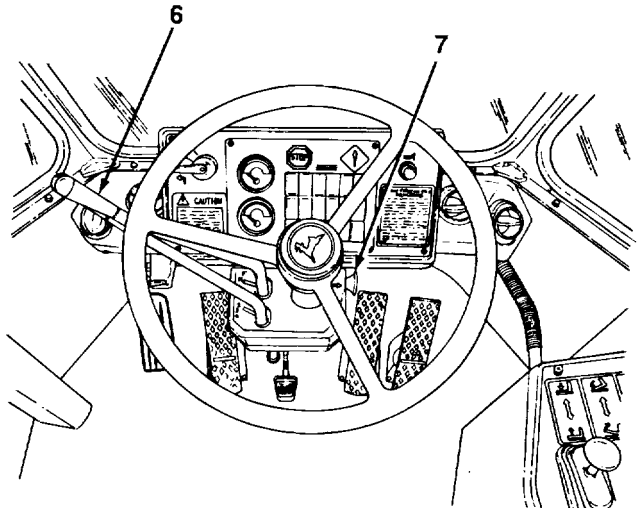

TA704496

2-11. START ENGINE (Con't).

- f. Engage clutch cut-off switch (3).

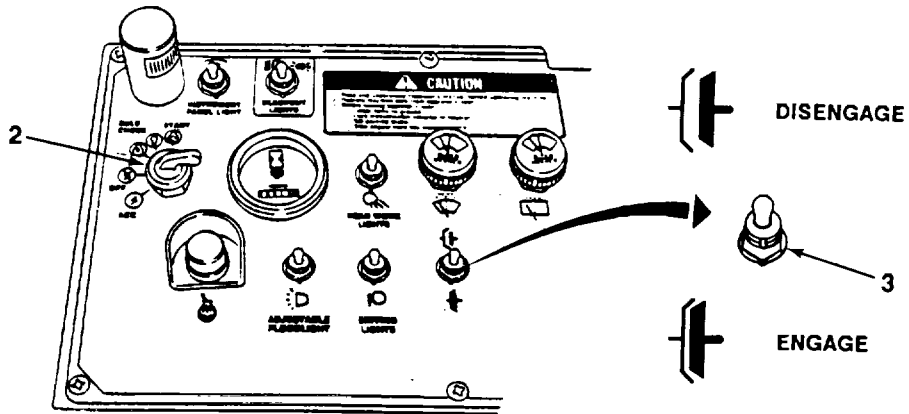

- g. Ensure that parking brake is set. If not, set parking brake by pushing down on parking brake pedal (9).
- h. Depress accelerator pedal (8) approximately one-third of full travel and hold.

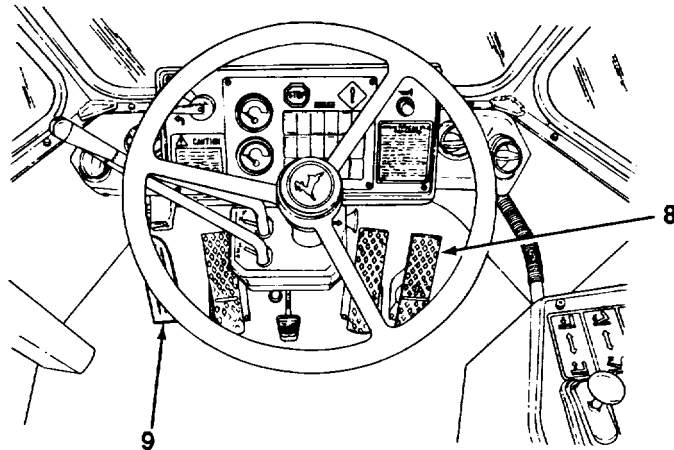

TA704497

2-11. START ENGINE (Con't).

CAUTION

DO NOT operate starter motor for more than 20 seconds at a time. After 20 seconds, allow starter motor to cool for at least two minutes before attempting to start engine again. Excessive heating of starter motor may result in damage or early starter failure.

- i. Turn ignition switch (2) to START position.
- j. When engine starts, release ignition switch (2) and accelerator pedal (8)
- k. Stop engine indicator (4) should go out approximately 10 seconds after engine starts. If it does not, shut down engine and notify Unit Maintenance.

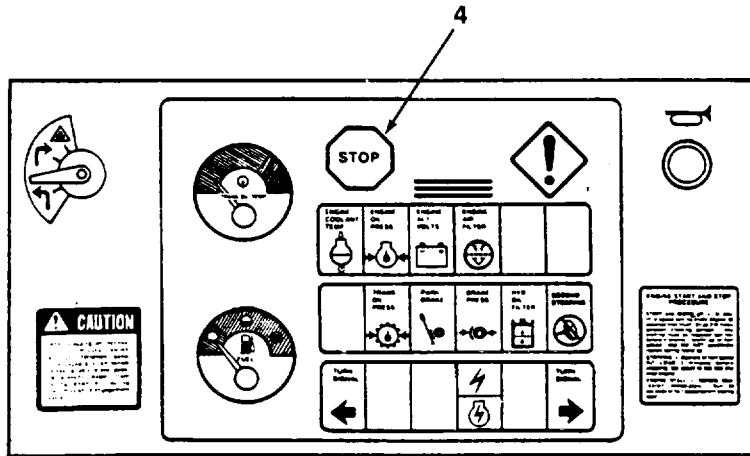

TA704498

2-12. OPERATE TRANSMISSION CONTROLS.

- a. Pull out on neutral lock button (2).
- b. Apply either service brake pedal (3) and hold.

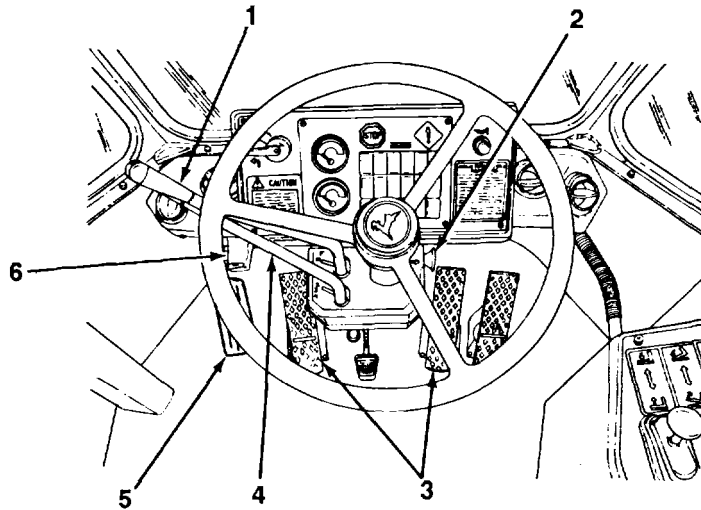

- c. Push down on parking brake pedal (5) and pull up on parking brake release handle (6) to release parking brake.
- d. Move direction selector lever (1) to F (Forward) or R (Reverse).

NOTE

Transmission will stay in range selected until speed range selector lever is manually moved.

- e. Move speed range selector lever (4) to desired speed range for expected terrain or road conditions.

NOTE

- **Speed range selector lever can be moved while forklift truck is in motion.**
- **There are four forward and three reverse speeds. If speed range selector lever is placed in fourth speed range while traveling in R (Reverse), transmission will remain in third speed range.**

- f. Move speed range selector lever (4) to higher or lower speed range to adjust for changing operating conditions.

TA704499

2-13. DRIVE FORKLIFT TRUCK.

- a. Start engine (see paragraph 2-11) and allow forklift truck to warm up.

CAUTION

Transmission may overheat if selected speed range is too high for loads being handled or for terrain over which forklift truck is operating. Select a lower speed range if overheating occurs to prevent damage to transmission.

- b. Set transmission controls to desired direction and speed range (see paragraph 2-12).
- c. For driving, raise forks, approximately 18 in. (46 cm) by moving fork control lever (1).

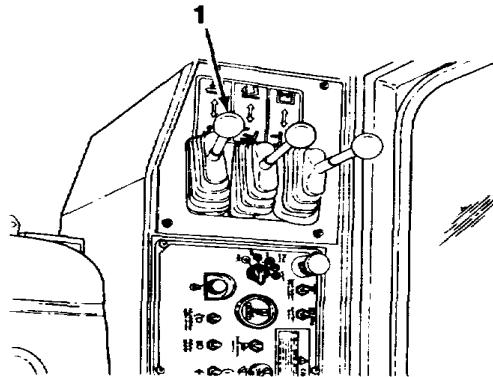

TA704500

2-13. DRIVE FORKLIFT TRUCK (Con't).**WARNING**

- **DO NOT** allow passengers to ride in cab or outside cab on forklift truck. Injury to personnel may result.
- Before moving forklift truck, ensure that all personnel are away from danger areas of forklift truck. Specifically, check to ensure that no one is between forward and rear sections of forklift truck. Failure to follow this warning may result in injury or death to personnel.

- Release service brake pedal (3) and press accelerator pedal (2) to start forklift truck in motion.
- Rotate steering wheel (4) right or left to operate power steering valve and to move forklift truck in right or left direction.
- Accelerate slowly to prevent slamming of power train components and to ensure that control of vehicle is maintained.
- To stop forklift truck, release accelerator pedal (2) and apply either service brake pedal (3).

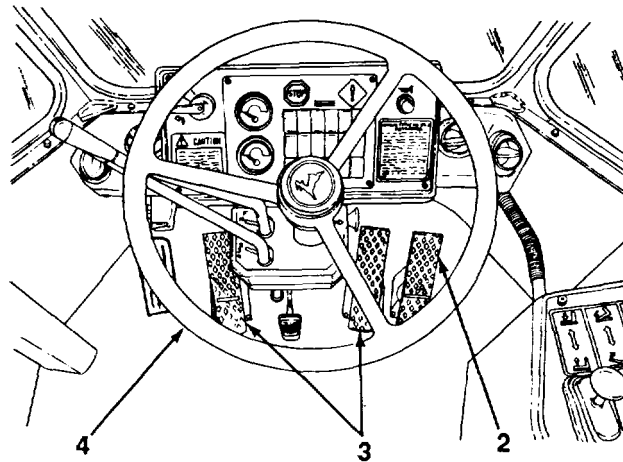
**2-14. DRIVING TIPS.**

- Travel with forks in lowest position that will clear obstacles, approximately 18 inches (46 cm).
- Adjust travel speed to terrain and road conditions in work area.

TA704501

2-14. DRIVING TIPS (Con't).

- c. Avoid sudden starts and stops, especially with a load on forks.
- d. Reduce speed when going around corners.
- e. Avoid driving on a slope whenever possible.
- f. Travel up a slope in forward gear and down a slope in reverse gear. Keep forks low to ground when traveling up or down slopes.
- g. Select lowest range possible when traveling down a slope. Do not allow engine to overheat.

WARNING

Never allow forks or load to contact power lines. If forklift truck must be operated in vicinity of power lines, follow these safety precautions. Failure to follow these procedures may result in death or serious injury.

- a. **Contact power company and have all power lines and ground wires turned off.**
- b. **DO NOT allow any portion of equipment close to power lines.**
- c. **Know maximum height and reach of forklift truck and build a suitable barricade around all power sources.**
- d. **Warn all personnel in work area of power source and electrocution hazard.**
- e. **If contact with a power source does occur, DO NOT step off the forklift truck. Stay on the vehicle until power is turned off or equipment is lowered and clear of power source.**
- f. **If fire or other conditions force operator to leave the forklift truck, Jump off and away keeping all parts of body clear of the equipment.**
- h. Avoid power lines. When power lines are in work area, have ground guide assist. If forks, or any other part of forklift truck, come in contact with power line stay in cab until contact is cleared. If you must leave cab during contact with power line, jump as far as possible. DO NOT climb down from cab.

2-15. PARK FORKLIFT TRUCK.

- a. Select as nearly level a surface as possible.
- b. Lower forks to ground.

2-15. PARK FORKLIFT TRUCK (Con't).

WARNING

DO NOT depend on direction selector lever alone to keep forklift truck from moving. **Always** apply parking brake. Failure to follow this warning may result in Injury to personnel.

- c. Move direction selector lever (1) to N (Neutral) position.
- d. Push in neutral lock button (2).
- e. Push down on parking brake pedal (3) to apply parking brake.

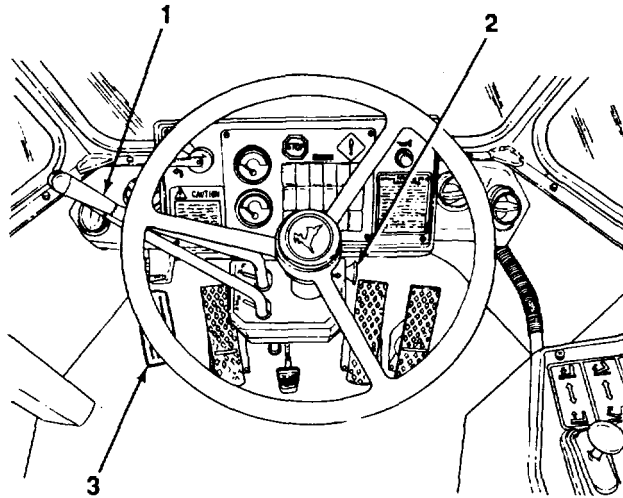

TA704502

2-16. SHUT DOWN ENGINE.

CAUTION

Shutting down engine without performing step a could damage turbocharger.

- a. Run engine at approximately one-half speed for two to three minutes.
- b. Release accelerator pedal (1) and allow engine to return to idle speed.

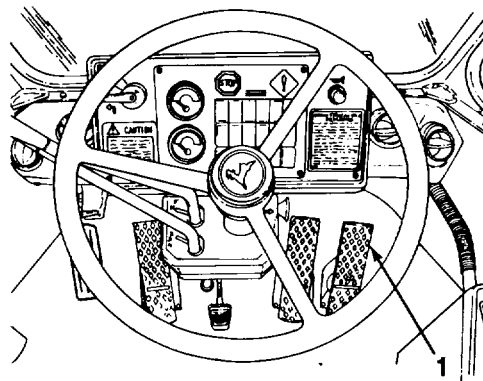

- c. Move ignition switch (2) to OFF position.

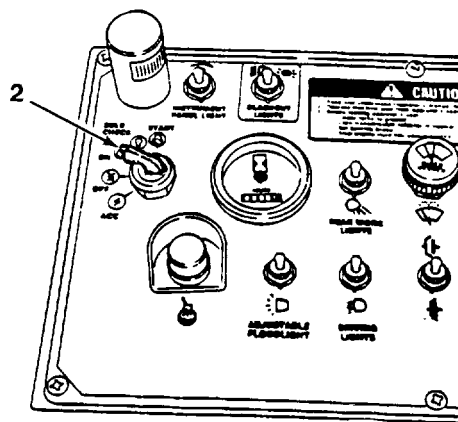

TA704503

2-16. SHUT DOWN ENGINE (Con't).

d. Move battery disconnect switch (3) to OFF position.

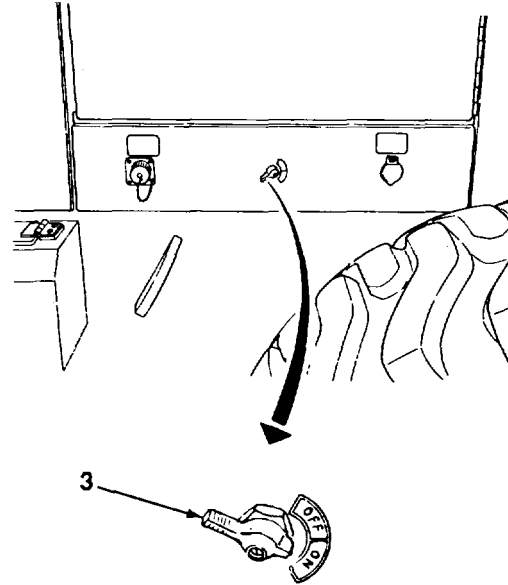
**2-17. OPERATE ATTACHMENT FUNCTIONS.****NOTE**

- Due to variety of loads and operating conditions, specific operating instructions are not provided; only general guidelines are provided.
- Attachment functions are controlled by three manually operated control valves.

a. When Increased engine speed is required to ensure that enough power is provided to perform the mission:

(1) Disengage clutch cut-off switch (1).

TA704504

2-17. OPERATE ATTACHMENT FUNCTIONS (Con't).

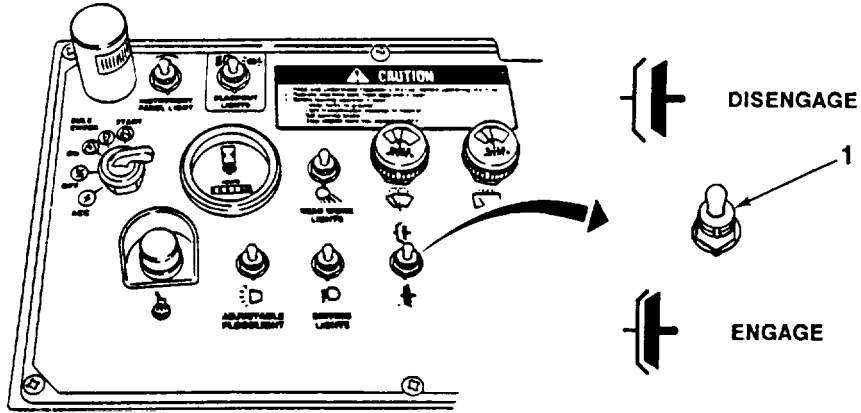

- (2) Press left service brake pedal (2) to disconnect clutch and ensure that forklift truck does not move while using forks to load or unload equipment.

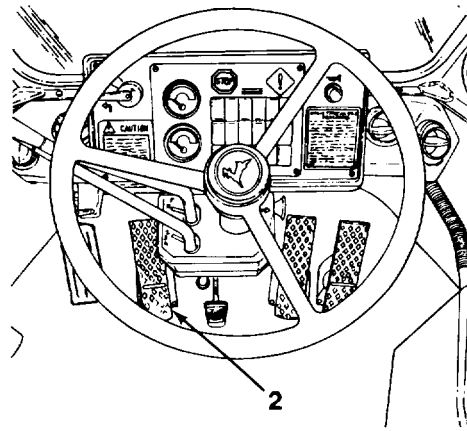

TA704505

2-17. OPERATE ATTACHMENT FUNCTIONS (Con't).

b. To raise forks, pull back on fork control lever (3). Rate of speed that forks raise will vary with speed of engine and how far back fork control lever is pulled.

c. To lower forks, push forward on fork control lever (3).

d. To tilt forks forward and down, push forward on fork tilt control lever (4).

e. To tilt forks rearward and up, pull back on fork tilt control lever (4).

f. To move forks further apart, push forward on fork spacing control lever (5).

g. To move forks closer together, pull back on fork spacing control lever (5).

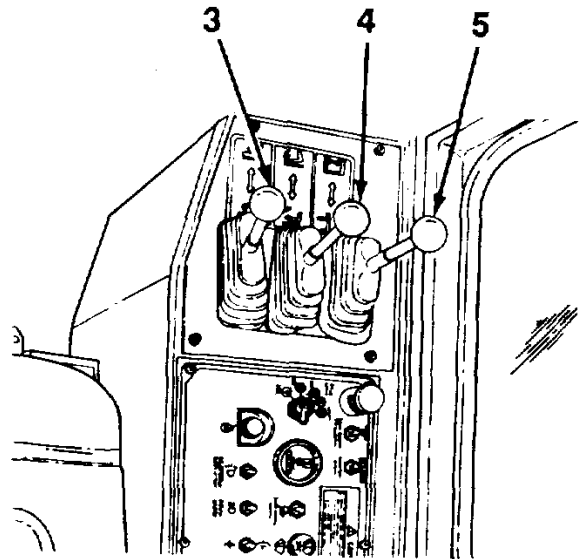
**2-18. REMOVE AND INSTALL CONVEYORIZED FORK ATTACHMENTS.****NOTE**

Conveyorized fork attachments are stowed on mounting brackets on side of forklift truck when not in use.

a. Install Conveyorized Fork Attachments.

- (1) Notify Unit Maintenance to assist in removing two conveyorized fork attachments (5) from stowage location on side of forklift truck (2).
- (2) Place two conveyorized fork attachments (5) on ground in front of forklift truck (2).
- (3) Aline forks (1) with two conveyorized fork attachments (5) and move forklift truck (2) forward until forks are fully installed into conveyorized fork attachments.
- (4) Raise forks (1) off ground. Push two conveyorized fork attachments (5) completely on forks and insert two retaining pins (4).
- (5) Push four retaining rings (3) over ends of two retaining pins (4) to hold in place.

TA704506

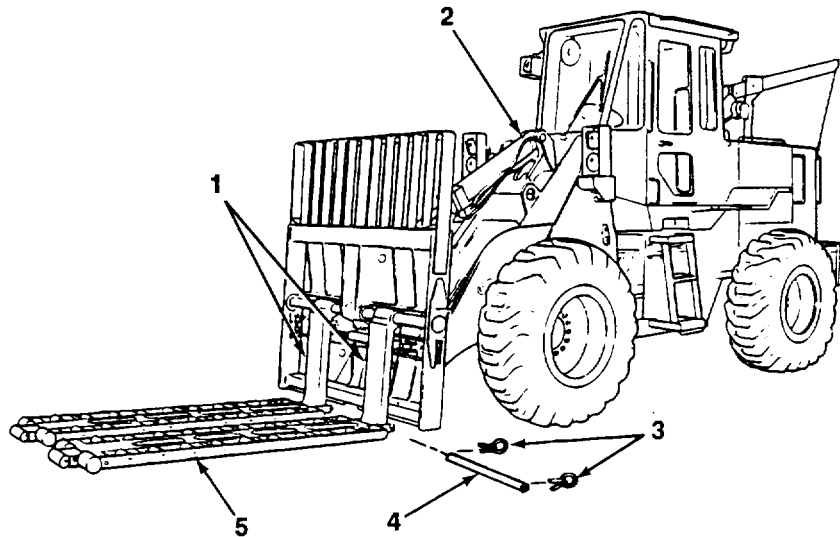
2-18. REMOVE AND INSTALL CONVEYORIZED FORK ATTACHMENTS (Con't).**b. Remove Conveyorized Fork Attachments.**

- (1) Raise forks (1) and remove four retaining rings (3) from two retaining pins (4).
- (2) Remove two retaining pins (4) from conveyorized fork attachments (5).
- (3) Slide two conveyorized fork attachments (5) half-way off forks (1).
- (4) Lower forks (1) and back away from two conveyorized fork attachments (5).
- (5) Notify Unit Maintenance to assist in stowage of conveyorized fork attachments (5) on side of forklift truck (2).

TA704507

2-18. REMOVE AND INSTALL CONVEYORIZED FORK ATTACHMENTS (Con't).

c. Reverse Conveyor Tips.

NOTE

Tips of conveyORIZED fork attachments can be reversed to accommodate operational requirements. One side of conveyor tip has a rubber bumper; the other side has a hard, tapered edge.

- (1) Raise forks (1) enough to gain access to bottom surface of conveyORIZED fork attachment (5).
- (2) Remove two retaining rings (7) from pin (6).
- (3) Remove pin (6) from conveyORIZED fork attachment (5).
- (4) Pull conveyor tip (8) out of end of conveyORIZED fork attachment (5).
- (5) Insert conveyor tip (8) into end of conveyORIZED fork attachment (5) and line up hole for pin (6).
- (6) Install pin (6) into conveyORIZED fork attachment (5) and conveyor tip (8).
- (7) Install two retaining rings (7) into pin (6). Fold over loop of each retaining ring to hold retaining rings in place.

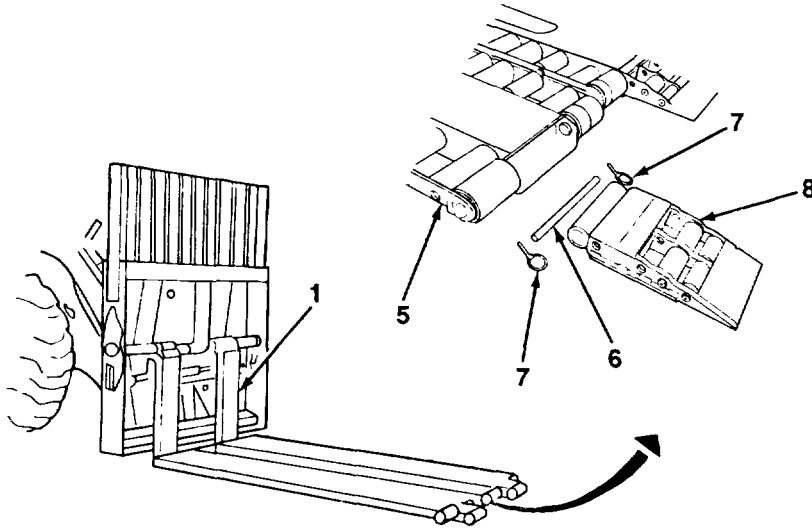

TA704508

2-19. OPERATE AIR COMPRESSOR.**NOTE**

See Unit Maintenance for an air hose prior to using air compressor.

- a. Start engine (see paragraph 2-11) and lower forks to ground.
- b. Ensure that direction selector lever is in N (Neutral) and that neutral lock button is pushed in.
- c. Ensure that parking brake is set.
- d. Leave engine running with qualified operator in cab.
- e. Open access door on right side of forklift truck.
- f. Connect air hose to air compressor outlet quick disconnect (1).
- g. Move air compressor switch (2) to ON position.
- h. When air compressor is no longer required, move air compressor switch (1) to OFF position.
- i. Relieve pressure in air hose. Remove air hose from air compressor outlet quick disconnect (1).
- j. Close access door and continue with assigned mission.

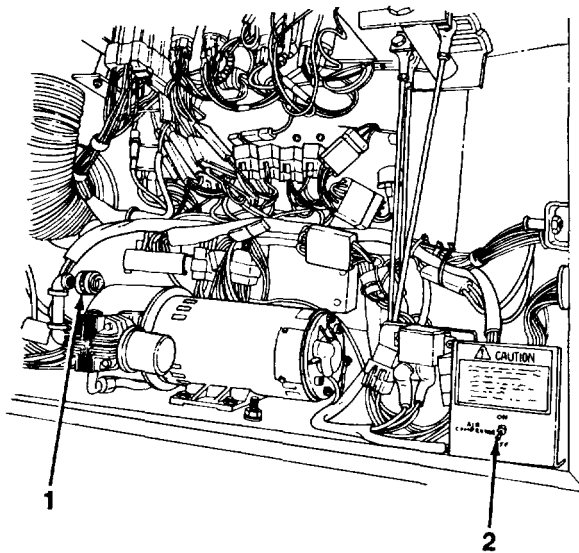

TA704509

2-20. OPERATE ON-BOARD CRANE.

WARNING

Crane Is heavy. Assistant Is required to raise or lower crane to various operating positions. Assistant may be required to help raise or lower load. Failure to follow this warning may result In Injury to personnel.

a. Crane can be raised or lowered by removing springlock pin (5) and retaining pin (9) from collar (6) and mast (4). Once crane is at desired level, insert springlock pin and retaining pin.

b. Crane hoist handle and cable spindle unit (2) can be moved up or down mast (4) by removing springlock pin (10) and retaining pin (3). Once crane hoist handle and cable spindle unit are at desired level, insert springlock pin and retaining pin.

c. Crane boom (8) can be moved in or out by removing springlock pin (7) and retaining pin (1), and moving crane boom in or out. Once desired position is reached, insert springlock pin and retaining pin.

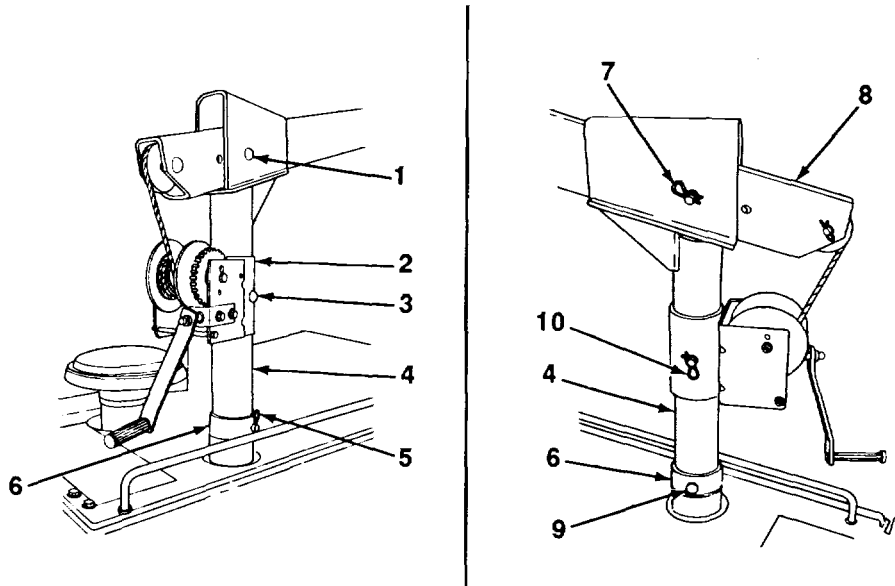

TA704510

2-20. OPERATE ON-BOARD CRANE (Con't).

d. To lift load with crane:

- (1) Position crane as required to perform load lifting.
- (2) Pull enough cable (12) from winch (11) to reach load.
- (3) Attach hook (14) at end of cable (12) to load, ensuring that safety catch (13) on hook is completely closed.
- (4) Turn hoist handle (15) to raise load. Move load into position.
- (5) Turn hoist handle (15) to lower load to stowage position. Remove hook (14) and cable (12).
- (6) Reel cable (12) onto winch (11).

WARNING

Crane is heavy. Assistant is required to raise or lower crane to various operating positions. Assistant may be required to help raise or lower load. Failure to follow this warning may result in injury to personnel.

- (7) Return crane to stowage position. Ensure that cable hook (14) is secured to forklift truck so that crane cannot move during movement of vehicle.

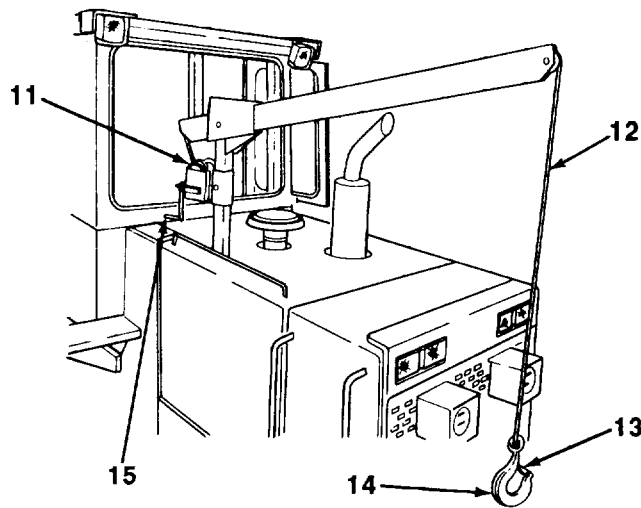

TA704511

2-21. OPERATE LIGHTS.**NOTE**

If engine is not running, battery disconnect switch must be set to ON position and Ignition switch must be in ON position for lights to operate.

a. Operate Service Lights.

- (1) Move DRIVING LIGHTS switch (4) up to turn on driving lights.
- (2) Move DRIVING LIGHTS switch (4) down to turn off driving lights.

b. Operate Worklights.

- (1) Move ADJUSTABLE FLOODLIGHT switch (5) up to turn on floodlight.
- (2) Move ADJUSTABLE FLOODLIGHT switch (5) down to turn off floodlight.
- (3) Move REAR WORK LIGHTS switch (3) up to turn on rear worklights.

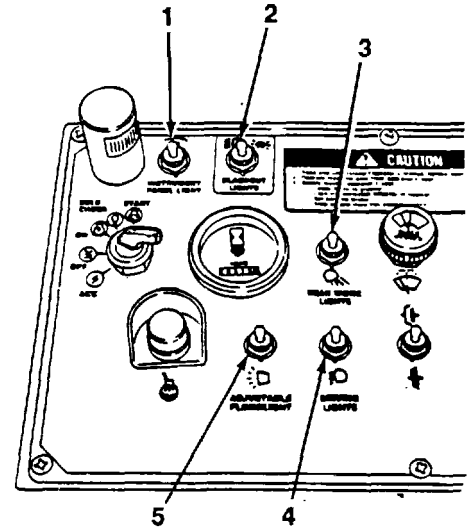

TA704512

- (4) Move REAR WORK LIGHTS switch (3) down to turn off rear worklights.

c. Operate Instrument Panel Light.

- (1) Move INSTRUMENT PANEL LIGHT switch (1) up to turn on instrument panel light.
- (2) Move INSTRUMENT PANEL LIGHT switch (1) down to turn off instrument panel light.

d. Operate Blackout Lights.

- (1) Move BLACKOUT LIGHTS switch (2) up to turn on blackout lights.
- (2) Move BLACKOUT LIGHTS switch (2) down to turn off blackout lights.

TA704512

2-21. OPERATE LIGHTS (Con't).

e. Operate Turn Signals and Emergency Flashers.

- (1) Move switch (6) down for left turn signal.
- (2) Move switch (6) up to first mark on instrument panel for right turn signal.
- (3) Move switch (6) to center position to turn off turn signal.
- (4) Move switch (6) all the way up for emergency flashers.
- (5) Move switch (6) to center position to turn off emergency flashers.

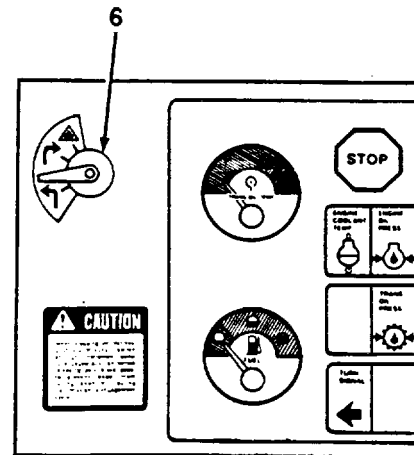

f. Operate Cab Domelight.

- (1) Move domelight switch (7) down to turn on domelight (8).
- (2) Move domelight switch (7) up to turn off domelight (8).

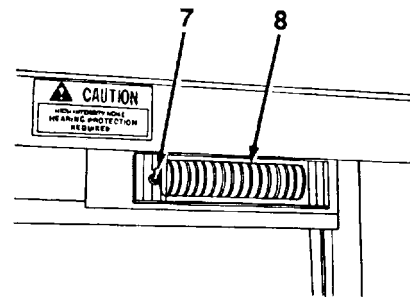

TA704513

2-22. OPERATE DEFROSTER FAN.

a. Move battery disconnect switch (1) to ON position.

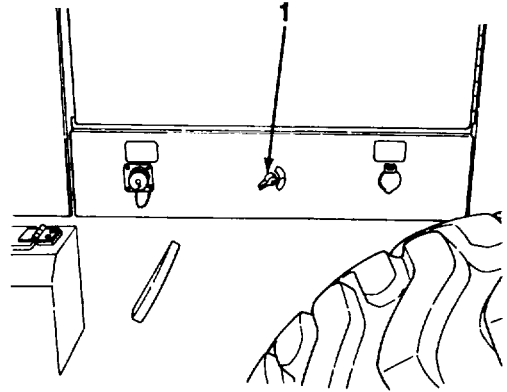

b. Move ignition switch (2) to ON position.

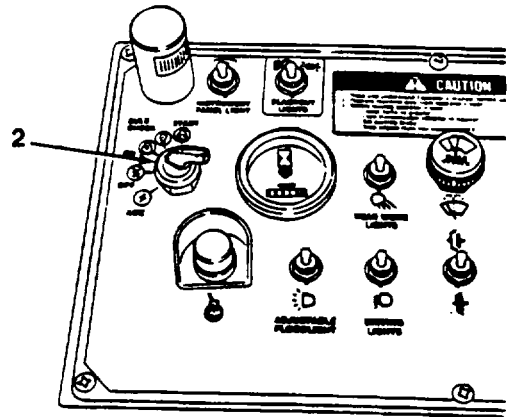

TA704514

2-22. OPERATE DEFROSTER FAN (Con't).

c. Move fan switch (3) to right for slow speed, to left for high speed, and to center to turn off fan (4).

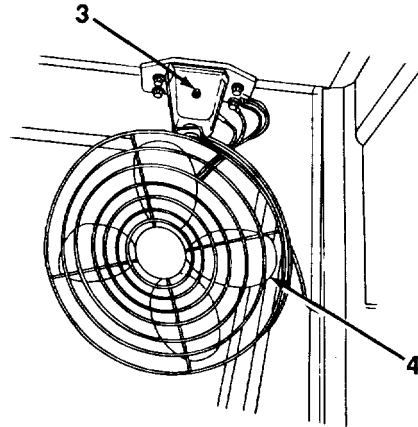
**2-23. OPERATE HEATER AND DEFROSTER.****NOTE**

Heater and defroster obtain heat from engine as it runs. If engine is not running, heat will not be available for these functions.

- a. Start engine (see paragraph 2-11) and bring forklift truck to normal operating temperature.
- b. Rotate heater temperature control knob (2) to make temperature setting cooler or warmer, as desired.
- c. Rotate heater blower control knob (3) to adjust fan speed from slower to faster, as desired.

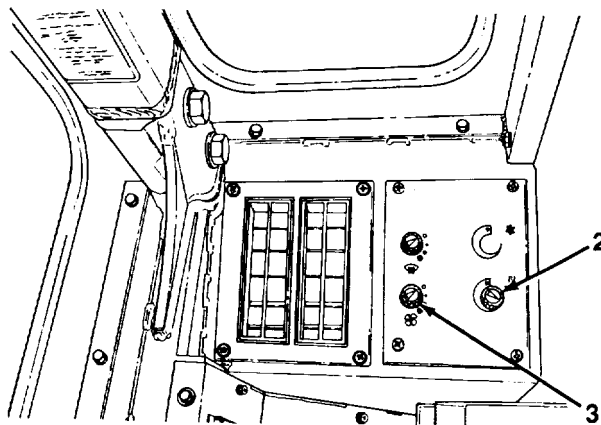

TA704515

2-23. OPERATE HEATER AND DEFROSTERS (Con't).

- d. Rotate defroster blower control knob (1) to adjust fan speed from slower to faster, as desired.

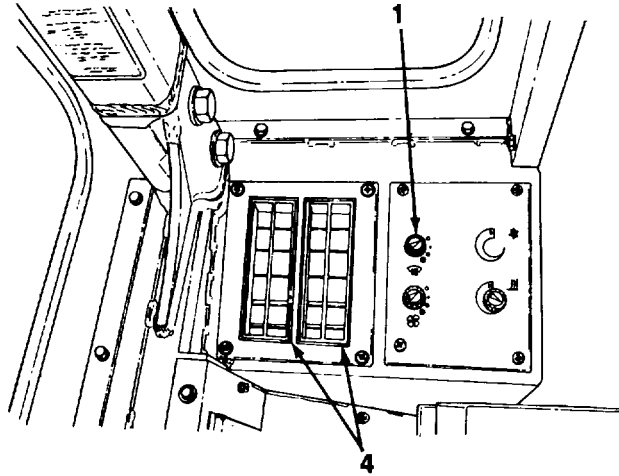

- e. Direct heater or defroster output to desired locations by adjusting air ducts (4) around windows and driver's seat.

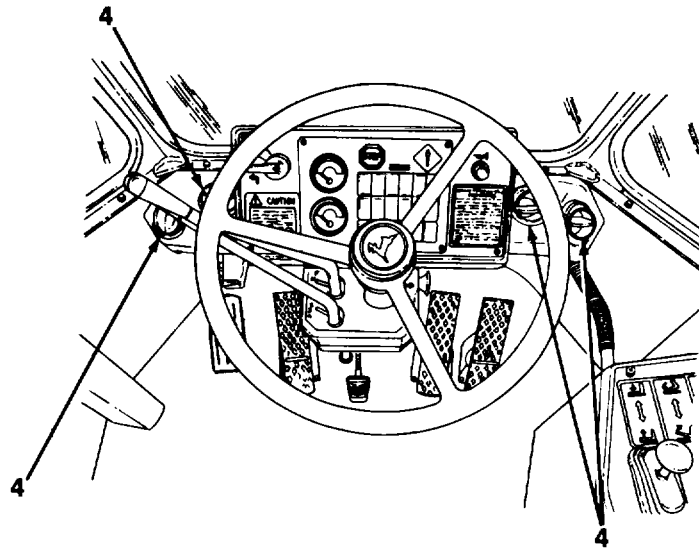

TA704516

2-24. OPERATE WINDSHIELD AND REAR WINDOW WIPERS AND WASHERS.

NOTE

Front and rear window wipers and washers are controlled by separate switches; however, both switches work in same way.

- a. Move battery disconnect switch (1) to ON position.

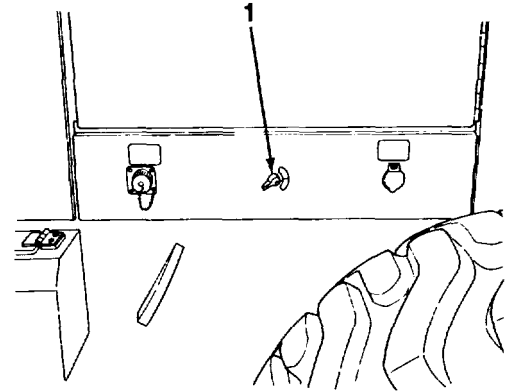

- b. Move ignition switch (2) to ON position.
- c. Rotate appropriate window wiper knob (3) rearward one click for slow speed and two clicks for fast speed.
- d. Push on appropriate window wiper knob (3) to activate window washer.

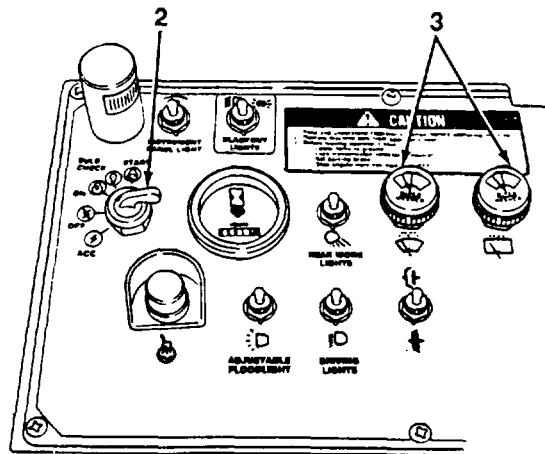

TA704517

2-25. LOCK FORKLIFT TRUCK FRAMES.**CAUTION**

This task should be performed only when forklift truck is to be transported on a different type of transportation system, towed, or maintenance is to be performed. Forklift truck must not be driven with frame locked, as forklift truck cannot be steered.

- a. Using steering wheel, center steering cylinders as closely as possible.
- b. Shut down engine (see paragraph 2-16).
- c. Remove two retaining pins (3).
- d. Slide steering locking bar (2) between hole in engine frame (4) and hole in attachment frame (1).
- e. Install retaining pins (3) to hold steering locking bar (2) in place.

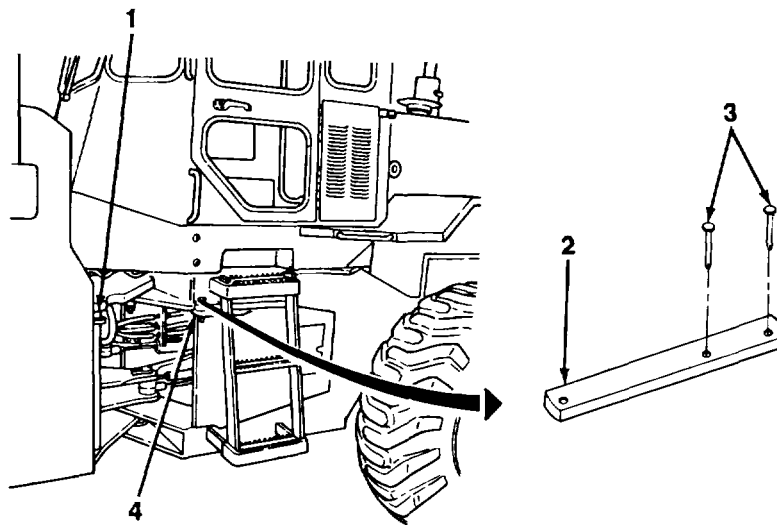

TA704518

Section IV. OPERATION UNDER UNUSUAL CONDITIONS

2-26. NEW OR REBUILT ENGINE BREAK IN.

NOTE

- Perform this task only when your forklift truck has had a new or rebuilt engine installed.
- Task should be performed during first 50 operating hours of new or rebuilt engine.
- DO NOT overload engine for first 50 operating hours.
- DO NOT run engine at idle speed more than absolutely necessary for first 50 operating hours.

a. Frequently check gauges and indicators for signs of problems. If gauges or indicators indicate a problem, immediately shut down engine and notify Unit Maintenance.

b. Initially, engine is filled with SAE 10-W-30 break-in oil. At end of first 80- 100 hours, engine oil and engine oil filter must be changed.

2-27. SLAVE START FORKLIFT TRUCK.

WARNING

- When slave starting forklift truck, use NATO slave cables that DO NOT have loose or missing insulation.
- DO NOT proceed if suitable cables are not available.
- DO NOT use civilian-type Jumper cables.

CAUTION

- If "dead" forklift truck's engine does not start within 20 seconds, release ignition switch. Wait three to five minutes before repeating procedure to prevent overheating the starter and damaging batteries of "live" vehicle. If engine does not start after several attempts, Unit Maintenance must perform additional maintenance.
- Any vehicle with a 24-volt system is suitable for slave cable starting. DO NOT attempt to start this forklift truck with a 12-volt system vehicle.
- Under no circumstances can this forklift truck be started by being towed or pushed. Failure to follow this caution will cause damage to transmission.
- DO NOT attempt to slave start forklift truck with battery disconnect switch in ON position. Failure to follow this caution may result in damage to vehicle electrical system.

2-27. SLAVE START FORKLIFTTRUCK (Con't).

NOTE

- Before slave starting, ensure that checks have been made to determine whether problem is low or dead batteries. If one battery is missing, DO NOT attempt to slave start.
- If a vehicle other than another M544E forklift truck is used to slave start this forklift truck, refer to Operator's Manual for that vehicle for any special slave starting procedures.
- Notify Unit Maintenance for use of NATO slave cables, which are not stored on forklift truck.

a. Turn battery disconnect switch (2) to OFF position.

b. Connect NATO slave cable to slave receptacle (1) of "dead" forklift truck (3).

c. Connect other end of NATO slave cable to slave receptacle on "live" vehicle.

d. Start engine of "live" vehicle.

e. Start engine of "dead" forklift truck (3) (see paragraph 2-11).

f. Turn battery disconnect switch (2) to ON position.

g. Remove slave cable from "live" vehicle.

h. Remove slave cable from "dead" forklift truck (3).

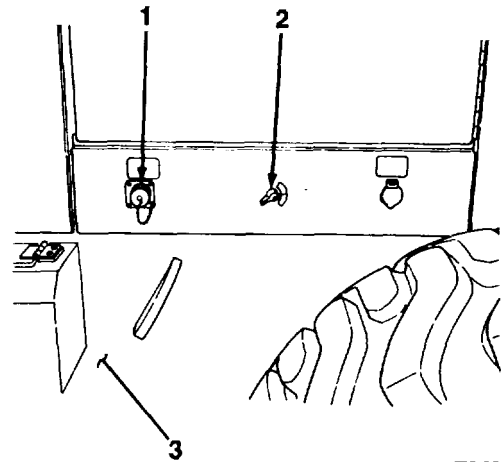

TA704519

2-28. TOW FORKLIFT TRUCK.**CAUTION**

- If engine is running and drive shafts are connected, forklift truck can be towed for a maximum distance of 6 mi (10 km) at speeds not to exceed 6 mph (10 kph). Towing greater distances or at higher speeds can cause damage to power train components.
- **DO NOT** attempt to start disabled forklift truck by towing it. This will cause damage to transmission.

NOTE

- If possible, run engine while forklift truck is being towed. Running engine will supply oil to service brake system and will lubricate transmission.
- If forklift truck must be moved more than 6 mi (10 km), **DO NOT** perform this task. Load forklift truck on suitable trailer and transport it to appropriate maintenance facility.

- a. If engine cannot be run, notify Unit Maintenance to remove front and rear drive shafts.

CAUTION

DO NOT attempt to tow forklift truck with any other means than large tow bar. Failure to follow this caution may result in damage to forklift truck.

- b. Connect legs of tow bar to two towing lugs on bottom edge of rear of forklift truck.
- c. Connect other end of tow bar to tow pintle of towing vehicle.
- d. Move direction selector lever to N (Neutral) and push in neutral lock button.
- e. Turn on emergency flashers on towing vehicle and also on towed forklift truck if power remains in batteries or engine is running.
- f. Release parking brake.
- g. If engine is running, operator should be in cab to operate forklift truck brakes and monitor indicators. If engine is not running, cab should be empty.
- h. If power is available, raise forks high enough to raise boom stop. Lower forks until boom rests on stops.

2-29. OPERATE IN EXTREME COLD.a. **General Guidelines.****WARNING**

DO NOT touch extremely cold metal, below -25°F (-320C). Bare skin can freeze to cold metal.

- (1) Special procedures must be used to operate the forklift truck during extreme cold temperatures.
- (2) Watch indicators closely for unusual readings. Notify Unit Maintenance Immediately if unusual readings occur.
- (3) Keep fuel tanks as full as possible during cold weather to prevent build up of water from condensation. If water enters fuel system, water could freeze and block fuel flow.
- (4) Do not attempt to operate equipment until defroster completely clears all windows. Do not attempt to use window wipers or washers until defrosters are operating at desired temperature.

b. **Engine Starting.****CAUTION**

Keep starting fluid can in place at all times to protect starting aid components.

NOTE

Starting aid is for use when outside temperature is at or below 30 °F (-1 °C).

- (1) Ensure that 110-volt extension cord is not connected to side of forklift truck. If extension cord is connected, disconnect and stow (see subparagraph d).
- (2) Perform paragraph 2-11, steps a through h.

2-29. OPERATE IN EXTREME COLD (Con't).

- (3) Move ignition switch (1) to START position.

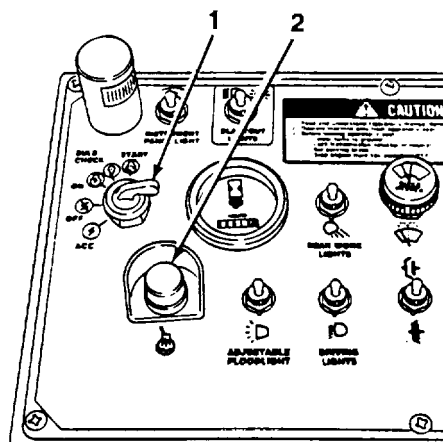
**CAUTION**

DO NOT apply more than three starting fluid applications per 20 second start attempt. If forklift truck does not start, wait two minutes before trying again. If forklift truck does not start after three tries, notify Unit Maintenance.

- (4) Depress starting aid switch (2) three seconds to fill starting fluid valve. Release switch to discharge starting fluid.
- (5) Release ignition switch (1).
- (6) When engine starts, run at half speed for approximately five minutes before operating any hydraulic functions or attempting to move forklift truck.

c. **Warm Up Hydraulic Oil.**

CAUTION

DO NOT actuate attachment control lever or turn steering wheel until engine has been run at half speed for five minutes. Failure to follow this caution may result in damage to equipment.

- (1) Slowly cycle lift, tilt, and spacing functions of forklift truck a number of times until actuating speeds appear to be normal.
- (2) Slowly turn steering wheel in either direction until steer limit is reached.
- (3) Hold steering wheel in position for a short time.

TA704520

2-29. OPERATE IN EXTREME COLD (Con't).

- (4) Turn steering wheel in other direction until steer limit is met. Hold for short time.
- (5) Repeat this procedure a number of times to warm hydraulic oil.
- (6) When moving forklift truck, select low range until transmission is brought up to operating temperature.

d. Operate Winterization Package.

NOTE

Winterization package should be connected to a 110-volt power source overnight or ten hours prior to forklift truck operation.

- (1) Ensure that ignition switch (1) and battery disconnect switch (3) are In OFF positions.
- (2) Remove 110-volt extension cord from compartment under driver's seat.
- (3) Connect 110-volt extension cord to 110-volt outlet (4) on side of forklift truck.

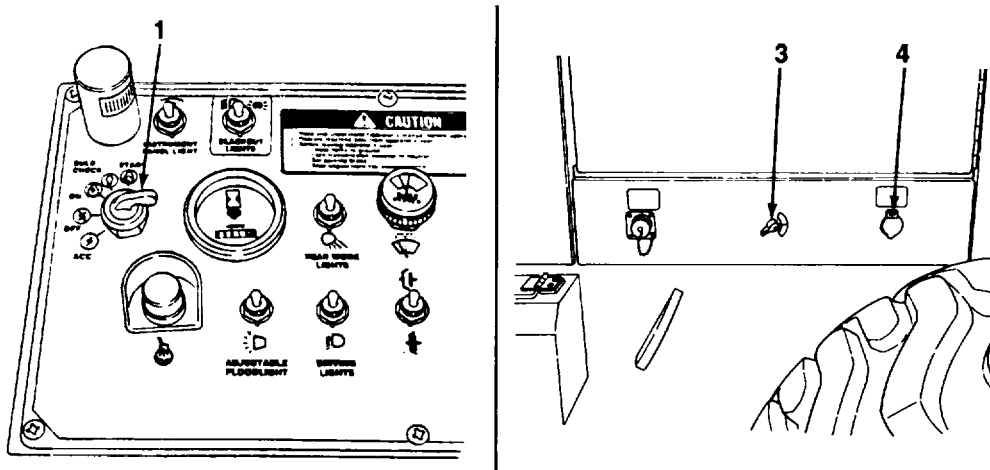

- (4) Connect other end of 110-volt extension cord to 110-volt power source.
- (5) When no longer required, disconnect 110-volt extension cord from 110-volt power source.
- (6) Disconnect 110-volt extension cord from side of forklift truck.

TA704521

2-29. OPERATE IN EXTREME COLD (Con't).

- (7) Stow extension cord in compartment under driver's seat.
- (8) Start engine (see paragraph 2-11).

2-30. OPERATE IN EXTREME HEAT.**NOTE**

When operating under desert conditions, also refer to paragraph 2-33.

a. General Guidelines.

- (1) Preventive maintenance is critical when operating at high temperatures. Forklift truck systems must be kept cool, clean, and in good condition.
- (2) Check engine oil level (see paragraph 3-6), transmission oil level (see paragraph 3-7), and coolant level (see paragraph 3-8) frequently. Fluids evaporate or break down more quickly and seals are more likely to leak under extreme heat.
- (3) Use correct fluids and lubricating oils for high temperature (see LO 10- 3930-659-12). Ensure that only an antifreeze and potable water mixture is used in cooling systems.
- (4) Do not overfill when adding fluids. Find and use fill marks. Try to service fluids when outside temperature is at midpoint of temperature range for the day. This helps avoid fluid overflows, explosions, or low levels due to expansion and contraction during hottest part of day or coolest part or night.
- (5) Keep radiator clean and free of dirt or debris. Ensure that radiator fill cap is the correct pressure for the forklift truck and that it works correctly.
- (6) Keep transmission oil cooler screen free of dirt and debris.
- (7) Check often for any wetness or signs of leaks at cooling system lines, hoses, seals, seams, drain plugs, or hose connections. Ensure that hoses are not spongy or brittle, and check fan belts for cracks or breaks.
- (8) High temperatures can expand belts; have belts adjusted as necessary.
- (9) In hot climates with relatively high dew levels and high humidity, overnight condensation can affect fuel tank, fuel lines, and hydraulic system reservoir. Have Unit Maintenance drain fuel filter at least once weekly, and check hydraulic oil level sight gage for foamy oil appearance both morning and night.
- (10) Heat and sun cause more rapid deterioration of rubber, plastics, and other materials. Check tires more frequently for damage or wear. Visually check tires for proper inflation and have Unit Maintenance add air when tires are cold and at midpoint of temperature range for the day.

2-30. OPERATE IN EXTREME HEAT (Con't).

- (11) Severe heat increases pressure in closed pressurized systems, such as hydraulic system and cooling system, and increases the volume of liquids. Ensure that working pressure is within safety limits and use caution when removing hydraulic fill cap and, if necessary, radiator fill cap.
- (12) Try to keep forklift truck in shade, or at least partially covered, to lessen heat damage. Ensure that all window surfaces in cab area are covered.
- (13) When operating forklift truck in temperatures above 100°F (38°C), extra care must be taken to prevent overheating of engine and transmission. Temperatures may be between 10 °F to 20 °F (-12 °C to -7°C) hotter than normal. Monitor engine coolant high temperature indicator and transmission oil temperature gage. If the temperatures continue to rise, put forklift truck in neutral and rev up engine to approximately 1200 rpm until indicator goes out and gage drops back to a more normal operating temperature.
- (14) Operate in lowest gear range allowable for the job you are doing. Keep load lifted as low as possible to avoid overloading the forklift.
- (15) Do not open engine access doors with the engine running to attempt to cool down the engine. Opening these doors interferes with proper airflow and may increase heating or damage the engine.

b. Battery Checks.

- (1) Batteries do not hold their charges well in extreme heat. Battery specific gravity should be adjusted by Unit Maintenance for the expected temperatures, and ensure that only distilled water is used in batteries.
- (2) Have Unit Maintenance set the voltage regulator at the appropriate specification for your area.
- (3) Monitor charging system closely to ensure that batteries are not overcharging or undercharging.
- (4) Make sure that battery air vents are kept clean.
- (5) If forklift truck is not to be used for two days, remove batteries and store in a cool place.

c. Cab Operations.

- (1) Ensure that sufficient air is kept moving by use of defroster fan (see paragraph 2-22).
- (2) Operator fatigue will be greater during extreme heat; therefore, frequent operator changes or rest periods should be observed.

2-31. OPERATE IN MUD OR SNOW.

- a. When operating forklift truck in mud, sand, or snow, extra care must be taken to prevent overheating of engine and transmission due to greater resistance of ground surface. Use lowest range possible and closely monitor indicator lights.
- b. If wheels start to spin, ease off accelerator pedal and attempt to regain traction.

2-32. FORDING.

- a. Water obstacles can be forded to a depth of 15 in. (38.1 cm).
- b. After fording, check all fluids for signs of contamination and for proper levels (see LO 10-3930-659-12).

2-33. OPERATE IN DUSTY OR SANDY AREAS.**NOTE**

When operating under desert conditions, also refer to paragraph 2-30.

a. General Guidelines.

- (1) Dust and sand act as contaminants and abrasives which increase wear and damage.
- (2) Keep equipment lubricants clean. Lubricate enclosed seals through grease fittings more often, adding lubricant until clean lubricant comes out. Wipe clean all lubricating tools and lubrication points before lubricating. Wipe clean outside of seals and grease fittings after lubrication. Check that seals and fittings are not damaged.
- (3) Oils and grease act as a magnet for dust or sand and create sludge that clogs, damages, and increases wear on parts. Keep lubrication of exposed bearing surfaces to a minimum and use only what is absolutely necessary to reduce friction.
- (4) Check filters daily and keep filters clean. Clean air filters once daily. Check air system components for damage frequently so that engine will not be contaminated by dust or sand.
- (5) Do not let sand build up in skid plates. When combined with condensation or oil, sand can cause jamming of control linkages.
- (6) Keep fuel clean. When refueling, use a filter. Wipe around fill cap before removing, wipe nozzle clean before inserting, and cover exposed area during filling.

2-33. OPERATE IN DUSTY OR SANDY AREAS (Con't).

- (7) Electrostatic discharge is prevalent in a dry sandy environment and sand is a difficult surface on which to ground. When refueling your forklift truck from another vehicle, ensure that a metal circuit is maintained between fuel tanker and forklift, and that both vehicles are grounded. Ensure that battery disconnect switch is set to OFF position.
- (8) When performing maintenance, cover area being worked to prevent contamination by dirt or dust.
- (9) Park vehicle facing away from wind. Cover as much as possible. Cover windows to prevent abrasion.

b. Driving Tips.

- (1) Check engine air filter restriction indicator on instrument panel often to ensure that air flow is not restricted.
- (2) Traveling over rocky desert terrain can quickly damage tires. Check condition of tires frequently.
- (3) Travel over rocky desert terrain can damage frame, shear rivets, or loosen nuts and bolts. Check mounting bolts and nuts on wheels, skid plates, engine, transmission, and differentials after operation. Notify Unit Maintenance of loose mounting hardware.
- (4) After operations are completed, on a daily basis remove built-up sand from engine compartment and around drive shafts, wheels, and pivot points.

CHAPTER 3
MAINTENANCE INSTRUCTIONS

Section I. LUBRICATION INSTRUCTIONS

3-1. GENERAL.

NOTE

Lubrication procedures are performed at Unit Maintenance. You may be required to assist the mechanic.

Periodic servicing ensures that the forklift truck will operate at peak performance. The Lubrication Order, LO 10-3930-659-12, gives complete cleaning and lubricating instructions. Refer to NOTES for specific instructions on lubrication. Service intervals are based upon normal operation under normal conditions.

3-2. LUBRICATION ORDER, LO 10-3930-659-12.

A copy of the Lubrication Order (LO) is Issued with each forklift truck and must remain with it at all times. If you receive the forklift truck without a copy, immediately notify your supervisor.

REMEMBER:

- The time to change oil is when starting or other operations become sluggish, or when outside temperatures move out of the appropriate range for the type of oil currently in the forklift truck. Do not wait for the next normally scheduled oil change.
- When you are operating under extreme conditions, lubricants should always be changed more frequently than the normal intervals specified by the LO. Lubricants break down or become contaminated more frequently under extreme conditions.

Section II. TROUBLESHOOTING PROCEDURES

3-3. GENERAL.

a. This section provides information for identifying and correcting malfunctions which may develop while operating your forklift truck.

b. The Troubleshooting Symptom Index in paragraph 3-5 lists common malfunctions which may occur and refers you to the proper page in Table 3-1 for a troubleshooting procedure.

c. If you are unsure of the location of an item mentioned in troubleshooting, refer to paragraph 1-9.

d. Before performing troubleshooting, read and follow all safety instructions found in the Warning Summary at the front of this manual.

e. This section cannot list all malfunctions that may occur, nor all tests or Inspections and corrective actions. If a malfunction is not listed, or is not corrected by the listed corrective actions, notify Unit Maintenance.

f. When troubleshooting a malfunction:

(1) Locate the symptom or symptoms in paragraph 3-5 that best describe the malfunction.

(2) Turn to the page in Table 3-1 where the troubleshooting procedures for the malfunction in question are described. Headings at the top of each page show how each troubleshooting procedure is organized: MALFUNCTION, TEST OR INSPECTION (in step number order), and CORRECTIVE ACTION.

(3) Perform each step in the order listed until the malfunction is corrected. DO NOT perform any maintenance task unless the troubleshooting procedure tells you to do so.

3-4. EXPLANATION OF COLUMNS.

The columns in Table 3-1 are defined as follows:

a. **MALFUNCTION**. A visual or operational indication that something is wrong with the forklift truck.

b. **TEST OR INSPECTION**. A procedure to isolate the problem in a system or component.

c. **CORRECTIVE ACTION**. A procedure to correct the problem.

3-5. TROUBLESHOOTING SYMPTOM INDEX.

	Troubleshooting Procedure Page
BRAKE SYSTEM	
Service Brakes:	
Chattering.....	3-8
Not Working	3-8
ENGINE	
Abnormal Noise.....	3-6
Emits Excessive Exhaust:	
Black	3-5
Gray.....	3-5
Blue	3-5
White.....	3-5
Fails to Start in Cold Weather	3-7
Ignition Switch in START Position But Will Not Turn Over.....	3-4
Low Oil Pressure	3-6
Overheats.....	3-6
Starts But Does Not Continue to Run.....	3-5
Turns Over But Will Not Start.....	3-5
Will Not:	
Continue to Run But Starts	3-5
Start But Turns Over	3-4
Turn Over When Ignition Switch is in START Position	3-4
HYDRAULIC SYSTEM	
Operation Erratic:	
Boom.....	3-10
Fork.....	3-10
Functions are Slow	3-9
Oil Temperature is Excessively High.....	3-9
System Does Not Function.....	3-9
STEERING SYSTEM	
Constant Steering Required to Maintain Straight Travel.....	3-9
Slow.....	3-8
Hard to Steer	3-8
Will Not Steer:	
Left	3-8
Right.....	3-8

3-5. TROUBLESHOOTING SYMPTOM INDEX (Con't).

	Troubleshooting Procedure Page
TRANSMISSION	
Oil Temperature High (Red Zone).....	3-7
Forklift Truck Will Not Move In Either Direction.....	3-7

Table 3-1. Troubleshooting.

MALFUNCTION
TEST OR INSPECTION
CORRECTIVE ACTION

ENGINE

1. ENGINE WILL NOT TURN OVER WHEN IGNITION SWITCH IS TURNED TO "START" POSITION.

Step 1. Check position of direction selector lever.

Shift direction selector lever to N (Neutral).

CAUTION

DO NOT attempt to slave start forklift truck with battery disconnect switch in ON position. Damage to vehicle electrical system may result (see paragraph 2-27).

NOTE

Use NATO slave cables and slave receptacle located on right rear side of forklift truck to slave start forklift truck.

Step 2. Check position of battery disconnect switch. If battery disconnect switch is in OFF position, turn it to ON position.

Step 3. Check for loose or corroded battery terminals. If battery terminals are loose or corroded, notify Unit Maintenance.

Table 3-1. Troubleshooting (Con't).

MALFUNCTION**TEST OR INSPECTION****CORRECTIVE ACTION**

2. ENGINE TURNS OVER BUT WILL NOT START.

Step 1. Check fuel level on fuel gage with ignition switch In ON position. If empty, fill tank.

Step 2. Check for obstruction of fuel tank cap vent.

Loosen fuel tank cap and crank engine. If engine starts, notify Unit Maintenance.

Step 3. Check for restricted air cleaner.

Check engine air filter restriction indicator. If indicator light is on, clean primary air filter element (see paragraph 3-11) and air inlet cover.

Step 4. Engine turns over slowly. Notify Unit Maintenance.

3. ENGINE STARTS BUT DOES NOT CONTINUE TO RUN.

Check fuel gage with ignition switch in ON position.

If empty, fill fuel tank. If fuel is present, notify Unit Maintenance.

4. ENGINE EMITS EXCESSIVE BLACK OR GRAY EXHAUST SMOKE.

Check engine air filter restriction Indicator.

If indicator light is on, clean primary air filter element (see paragraph 3-11).

5. ENGINE EMITS EXCESSIVE BLUE OR WHITE EXHAUST SMOKE.

Check engine coolant level in see-through coolant recovery tank.

Allow engine to warm up to operating temperature. If engine fails to reach full operating temperature, notify Unit Maintenance.

Table 3-1. Troubleshooting (Con't).

MALFUNCTION
TEST OR INSPECTION
CORRECTIVE ACTION

6. ABNORMAL ENGINE NOISE.

Check engine oil level.

If engine oil level is low, fill to correct level (see LO 10-3930 659-12). If engine oil level is correct, notify Unit Maintenance.

7. LOW ENGINE OIL PRESSURE.

Check engine oil level.

If engine oil level is low, fill to correct level (see LO 10-3930- 659-12). If engine oil level is correct, notify Unit Maintenance.

8. ENGINE OVERHEATS.**WARNING**

DO NOT remove radiator fill cap unless engine is cold. This is a pressurized cooling system and escaping steam, hot water, or coolant will cause serious burns.

Step 1. Check coolant level in see-through coolant recovery tank.

If coolant level is low, obtain coolant mixture from Unit Maintenance and fill coolant recovery tank to correct level (see LO 10-3930-659-12).

Step 2. Check outside of radiator for obstructions.

Remove anything that blocks or impedes air flow.

Step 3. Check engine oil level.

If engine oil level is low, fill to correct level (see LO 10-3930- 659-12). If engine oil level is correct, notify Unit Maintenance.

Step 4. Check cooling system for damaged drive belts or leaking hoses.

Notify Unit Maintenance.

Table 3-1. Troubleshooting (Con't).

MALFUNCTION
TEST OR INSPECTION
CORRECTIVE ACTION

9. ENGINE FAILS TO START IN COLD WEATHER.

Step 1. Check whether starting aid was used during starting procedures.

Use starting aid (see paragraph 2-29).

Step 2. Check starting aid container contents.

If empty, notify Unit Maintenance.

*TRANSMISSION***10. FORKLIFT TRUCK WILL NOT MOVE IN EITHER DIRECTION.**

Step 1. Check whether parking brake is applied.

Release parking brake.

Step 2. Check transmission oil level.

If transmission oil level is low, fill to correct level (see LO 10- 3930-659-12). If transmission oil level is correct, notify Unit Maintenance.

Step 3. Check whether service brakes are locked.

If service brakes are locked, notify Unit Maintenance.

11. TRANSMISSION OIL TEMPERATURE HIGH (RED ZONE).

Step 1. Check for operation of forklift truck in too high a speed range.

Shift to lower speed range.

Step 2. Check for operation of forklift truck with load over 10, 000 lb (4540 kg).

Reduce load.

Step 3. Check outside of oil cooler for obstructions.

Remove anything that blocks or impedes air flow.

Table 3-1. Troubleshooting (Con't).

MALFUNCTION**TEST OR INSPECTION****CORRECTIVE ACTION**

Step 4. Check transmission oil level.

If transmission oil level is low, fill to correct level (see LO 1- 3930-659-12). If transmission oil level is correct, notify Unit Maintenance.

*BRAKE SYSTEM***12. SERVICE BRAKES CHATTERING OR NOT WORKING.**

Step 1. Check hydraulic system oil level.

If hydraulic oil level is low, fill to correct level (see LO 10-3930- 659-12). If hydraulic oil level is correct, notify Unit Maintenance.

Step 2. Check for foamy oil in hydraulic oil level sight gage.

If oil is foamy, notify Unit Maintenance.

*STEERING SYSTEM***13. FORKLIFT TRUCK WILL NOT STEER LEFT OR RIGHT.**

Check whether steering locking bar is installed.

Remove steering locking bar (see paragraph 2-25).

14. STEERING SLOW OR HARD.

Step 1. Check hydraulic system for cold oil.

Slowly turn steering wheel in either direction until steer limit is reached. Hold steering wheel in position for a short time. Turn steering wheel in other direction until steer limit is met. Repeat cycling a number of times to warm hydraulic oil.

Table 3-1. Troubleshooting (Con't).

MALFUNCTION
TEST OR INSPECTION
CORRECTIVE ACTION

Step 2. Check hydraulic oil level.

If hydraulic oil level is low, fill to correct level (see LO 10-3930- 659-12). If hydraulic oil level is correct, notify Unit Maintenance.

15. CONSTANT STEERING REQUIRED TO MAINTAIN STRAIGHT TRAVEL.

Check for air in hydraulic system.

If oil is foamy in hydraulic oil level sight gage, notify Unit Maintenance.

HYDRAULIC SYSTEM

16. HYDRAULIC SYSTEM DOES NOT FUNCTION.

Check hydraulic oil level.

If hydraulic oil level is low, fill to correct level (see LO 10-3930- 659-12). If hydraulic oil level is correct, notify Unit Maintenance.

17. HYDRAULIC FUNCTIONS ARE SLOW.

Step 1. Check hydraulic system for cold oil.

Cycle boom and fork attachments until oil reaches normal operating temperature.

Step 2. Check outside of oil cooler for obstructions.

Remove anything that blocks or impedes air flow.

18. HYDRAULIC OIL TEMPERATURE EXCESSIVELY HIGH.

Check for excessive loads.

Reduce loads to lifting capacity of forklift truck (see paragraph 1-10).

Table 3-1. Troubleshooting (Con't).

MALFUNCTION
TEST OR INSPECTION
CORRECTIVE ACTION

19. BOOM AND FORK OPERATION ERRATIC.

Check for air In hydraulic system.

If oil Is foamy In hydraulic oil level sight gage, notify Unit Maintenance.

Section III. MAINTENANCE PROCEDURES

3-6. CHECK AND FILL ENGINE OIL.

a. Check Engine Oil Level.

NOTE

If forklift truck has been running, park on level ground and wait 10 minutes for oil to drain into oil pan. Oil must be between ADD and FULL marks on engine oil level gage.

- (1) Remove engine oil level gage (1), wipe clean with rag (Item 7, Appendix D), and install into engine oil level gage tube (3).
- (2) Remove engine oil level gage (1). Oil level must be at FULL mark. Install engine oil level gage into engine oil level gage tube (3).

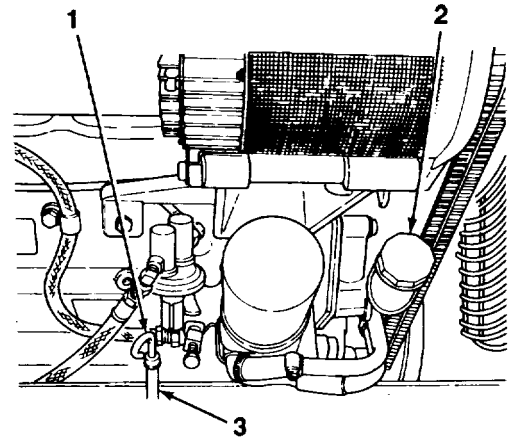

TA704522

b. Add Engine Oil.

- (1) Remove engine oil fill cap (2). Add engine oil as necessary and install engine oil fill cap (see LO 10-3930-659-12).
- (2) Check engine oil level.

3-7. CHECK AND FILL TRANSMISSION OIL.**a. Cold Check of Transmission Oil Level.**

- (1) Start engine (see paragraph 2-11).
- (2) Turn and remove transmission oil level gage (1), wipe clean with rag (Item 7, Appendix D), and install into transmission oil level gage fill tube (2).
- (3) Remove transmission oil level gage (1). Oil level must be at COLD mark. Install and turn transmission oil level gage into transmission oil level gage fill tube (2).

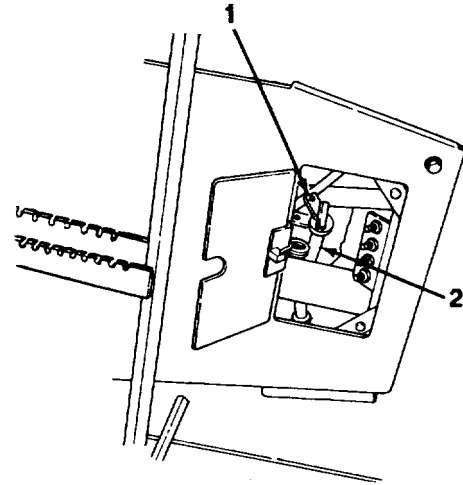

TA704523

b. Add Transmission Oil.

- (1) Turn and remove transmission oil level gage (1). Add transmission oil as necessary and install transmission oil level gage (see LO 10-3930- 659-12).
- (2) Check transmission oil level.

c. Hot Check of Transmission Oil Level.

- (1) Start engine (see paragraph 2-11), engage parking brake (7), hold service brakes (5), and lower forks to ground.
- (2) Position direction selector lever (3) in F (Forward) and speed range selector lever (6) In fourth position.
- (3) Operate engine at fast Idle for 30 seconds. Reduce engine speed to a slow Idle and place direction selector lever (3) in N (Neutral) for 15 seconds. Repeat this step until transmission oil reaches normal operating temperature.
- (4) Push in neutral lock button (4).

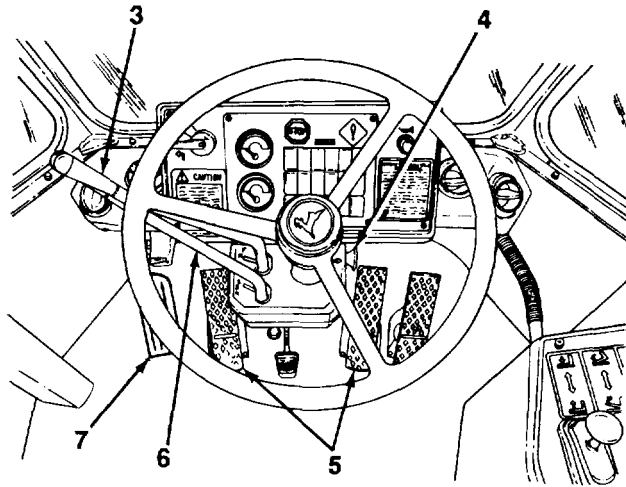
3-7.CHECK AND FILL TRANSMISSION OIL (Con't).

- (5) Turn and remove transmission oil level gage (1), wipe clean with rag (Item 7, Appendix D), and install into transmission oil level gage fill tube (2).
- (6) Check transmission oil level with engine at a slow Idle. Oil must be between COLD and HOT marks on transmission oil level gage.

TA704524

3-8. CHECK AND FILL COOLANT LEVEL.a. Check Coolant Level.**NOTE**

If conveyolized fork attachments are installed on side of forklift truck, make visual check of coolant level from access hole in top of engine hood.

- (1) Visually check coolant level in coolant recovery tank (1). Coolant level must be between HOT and COLD lines.

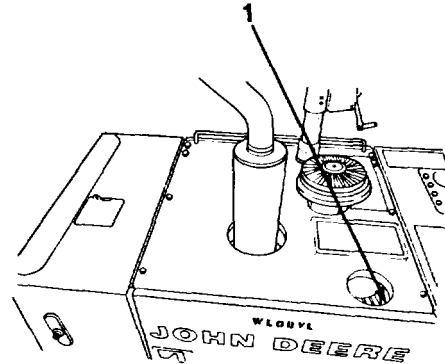

TA704525

WARNING

DO NOT remove radiator fill cap unless engine is cold. This is a pressurized cooling system and escaping steam, hot water, or coolant will cause serious burns.

NOTE

Only check coolant level in radiator if coolant recovery tank is empty.

- (2) Remove radiator fill cap (3). Coolant level must be at bottom of filler neck.

3-8.CHECK AND FILL COOLANT LEVEL (Con't).

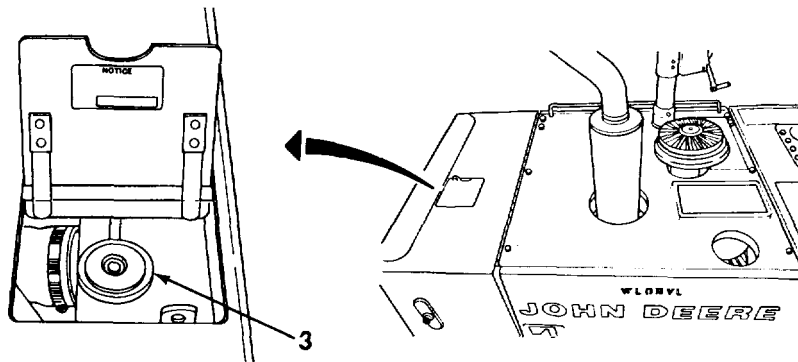

b. Fill Radiator and Coolant Recovery Tank.

WARNING

DO NOT remove radiator fill cap unless engine is cold. This is a pressurized cooling system and escaping steam, hot water, or coolant will cause serious burns.

NOTE

Coolant mixture must be obtained from Unit Maintenance.

- (1) Remove radiator fill cap (3) and fill radiator with coolant solution to bottom of fill neck (see LO 10-3930-659-12). Install radiator fill cap.
- (2) Remove tank cap (2). Fill coolant recovery tank (1) to COLD line with coolant solution (see LO 10-3930-659-12). Install tank cap.

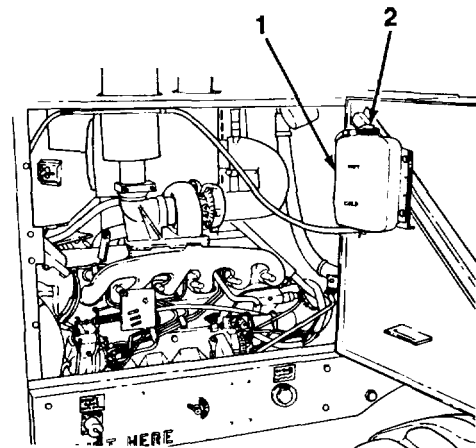

TA704526

3-9. CHECK AND FILL WINDSHIELD WASHER BOTTLE.

Visually check windshield washer bottle (1). If low or empty, remove cap (2) and fill with windshield washer solution (Item 1, Appendix D). Install cap on washer bottle.

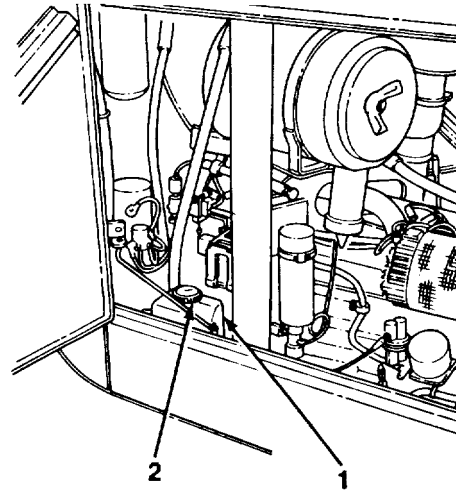

TA704527

3-10. CHECK AND FILL HYDRAULIC SYSTEM RESERVOIR.**a. Check Hydraulic Oil Level.**

- (1) Park forklift truck on level ground with forks lowered to ground (see paragraph 2-15).
- (2) Visually check hydraulic level sight gage (2). Oil must be visible.
- (3) If hydraulic oil is foamy, notify Unit Maintenance.

b. Fill Hydraulic Oil Reservoir.

- (1) Remove hydraulic reservoir fill cap (1) and add hydraulic oil until oil is visible in hydraulic level sight gage (2) (see LO 10-3930-659-12). Replace hydraulic reservoir fill cap.

3-10. CHECK AND FILL HYDRAULIC SYSTEM RESERVOIR (Con't).

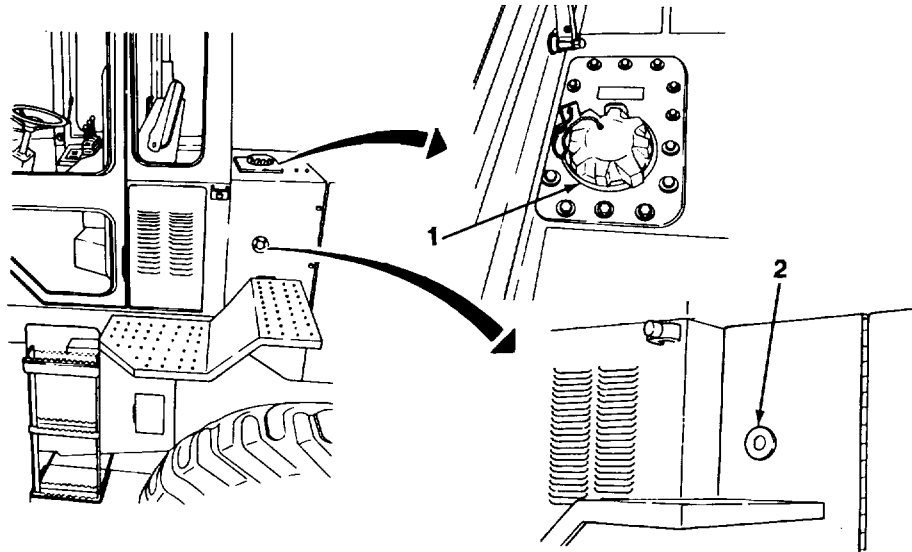

3-11. CHECK AND CLEAN ENGINE PRIMARY AIR FILTER AND UNLOADER VALVE.

WARNING

If NBC exposure is suspected, all engine air cleaner air filter media should be handled by personnel wearing protective equipment. Consult your NBC Officer or NBC NCO for appropriate handling or disposal procedures.

a. Check and Clean Engine Primary Air Filter.

- (1) Loosen wingnut (1) and remove air cleaner cover (2).

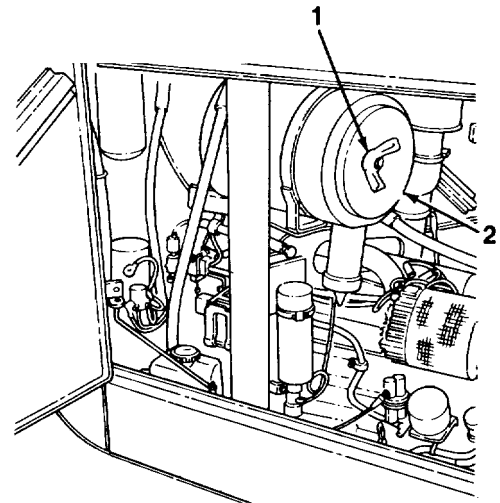

TA704528

3-11. CHECK AND CLEAN ENGINE PRIMARY AIR FILTER AND UNLOADER VALVE (Con't).

- (2) Loosen wingnut (6) and remove primary air filter (5) from air cleaner housing (4). Check air filter for damage or dirt.
- (3) Clean primary air filter (5) as shown.
- (4) Tap primary air filter (5) with palm of hand to remove dust.

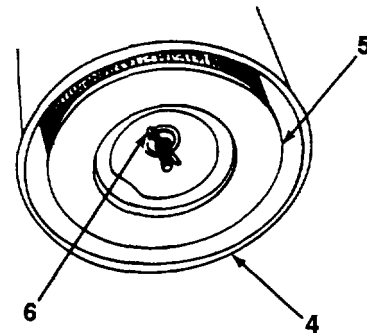

WARNING

Compressed air used for cleaning or drying purposes, or for clearing restrictions, should never exceed 30 psi (207 kPa). Wear protective clothing (goggles/shield, gloves, etc.) and use caution to avoid injury to personnel.

- (b) Direct compressed air up and down pleats of air filter element, from inside to outside, to remove dirt from primary air filter (5).
- (4) Install primary air filter (5) in air cleaner housing (4) and tighten wingnut (6).
- (5) Position air cleaner cover (2) in place and secure with wingnut (1).

b. Clean Unloader Valve.

Squeeze unloader valve (3) to remove dust from air cleaner.

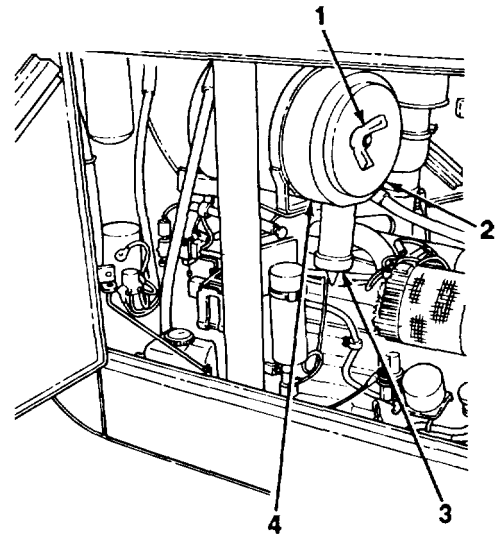

TA704529

3-12. CHECK AND CLEAN CAB AIR FILTERS.**WARNING**

If NBC exposure is suspected, all air filter media should be handled by personnel wearing protective equipment. Consult your NBC Officer or NBC NCO for appropriate handling or disposal procedures.

a. Check and Clean Cab Recirculating Air Filter.

- (1) Loosen two screws (1) securing filter screen (2) and air filter (3) to rear of cab behind seat. Remove air filter from filter screen. Check air filter for damage or dirt.
- (2) Wash air filter (3) in warm, soapy (Item 2, Appendix D) water. Flush with clean water and let air dry.
- (3) Install air filter (3) in filter screen (2) and secure to rear of cab with two screws (1).

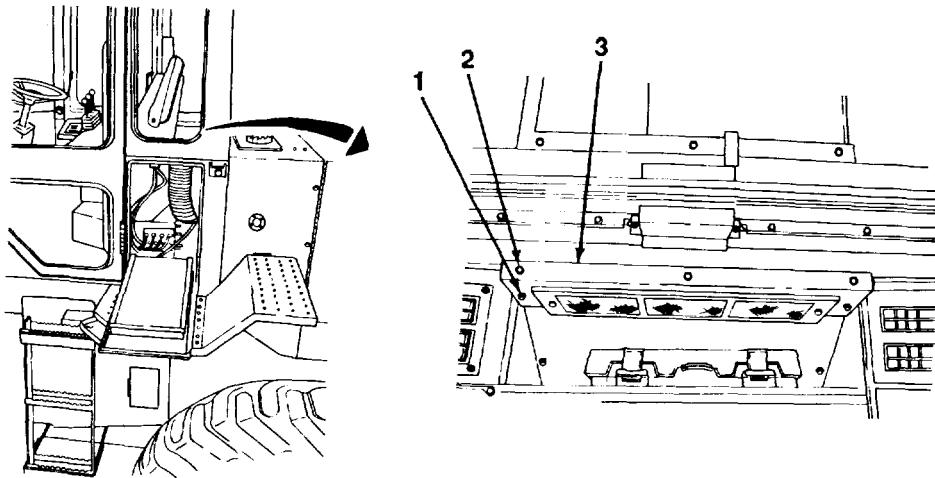

TA704530

3-12. CHECK AND CLEAN CAB AIR FILTERS (Con't).**b. Check and Clean Cab Fresh Air Filter.**

- (1) Open fresh air filter door (7), remove four wingnuts (5), and filter mounting frame (4). Remove air filter (6) from door. Check air filter for damage or dirt.
- (2) Clean air filter (6) by:
 - (a) Tapping air filter (6) on flat surface with dirty side down.

WARNING

Compressed air used for cleaning or drying purposes, or for clearing restrictions, should never exceed 30 psi (207 kPa). Wear protective clothing (goggles/shield, gloves, etc.) and use caution to avoid injury to personnel.

- (b) Using compressed air opposite to normal air flow, remove dirt from air filter (6).
- (3) Install air filter (6) on door (7), with air flow arrow pointing up. Position mounting frame (4) over air filter and secure with four wingnuts (5). Close air filter door.

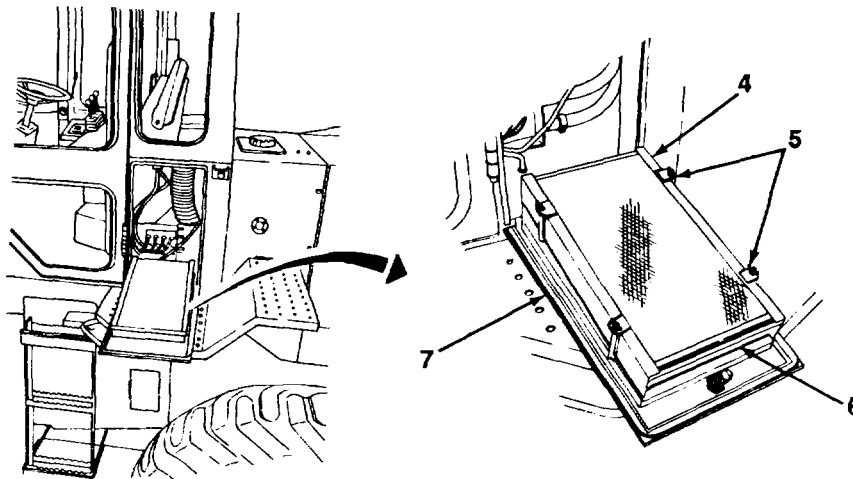

TA704531

3-13. REFUELING PROCEDURES.**WARNING**

Diesel fuel is combustible. DO NOT smoke or allow open flame near fuel tank. Failure to follow this warning will result in death or serious injury to personnel. If you are burned, immediately seek medical aid.

- a. Park forklift truck on level ground (see paragraph 2-15) and shut down engine (see paragraph 2-16).
- b. Open radiator grille door (1) and rotate locking tab (3) down to hold radiator grille door open.
- c. Open fuel tank fill tube cap (2).

NOTE

DO NOT overfill fuel tank. Fuel tank should be filled only to bottom of fill tube.

- d. Fill fuel tank as necessary.
- e. Close fuel tank fill tube cap (2).
- f. Rotate locking tab (3) up to stowage position and close radiator grille door (1).

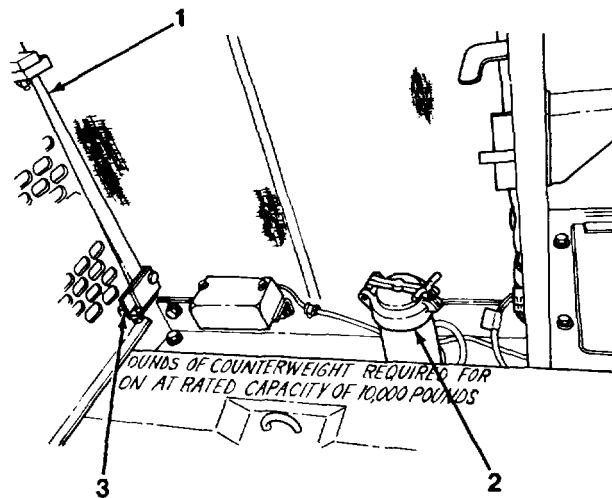

TA704532

**APPENDIX A
REFERENCES**

A-1. SCOPE.

This appendix lists all forms, field manuals, technical manuals, and other publications referenced in this manual and which apply to the operation of the M544E Forklift Truck.

A-2. PUBLICATION INDEXES.

The following indexes should be consulted frequently for latest changes or revisions and for new publications relating to material covered in this technical manual.

Consolidated Index of Army Publications and Blank Forms	DA Pam 25-30
US Army Equipment Index of Modification Work Orders.....	DA Pam 750-10

A-3. FORMS.

Refer to DA Pam 738-750, *The Army Maintenance Management System (TAMMS)*, for instructions on the use of maintenance forms.

Equipment Inspection and Maintenance Worksheet	DA Form 2404
Product Quality Deficiency Report	SF Form 368
Recommended Changes to Equipment Technical Publications	DA Form 2028-2
Recommended Changes to Publications and Blank Forms	DA Form 2028

A-4. FORKLIFT TRUCK PUBLICATIONS.

Lubrication Order for Truck, Forklift: Adverse Terrain, 10, 000 Lb Capacity, M544E (NSN 3930-01-301-8250).....	LO 10-3930-659-12
Warranty Program for Truck, Forklift: Adverse Terrain, 10, 000 Lb Capacity, Diesel Engine Driven, MHE-268 (NSN 3930-01-298-5737).....	TB 10-3930-659-14

A-5.FIELD MANUALS.

Basic Cold Weather Manual.....	FM 31-70
Camouflage	FM 20-3
Desert Operations	FM 90-3
Evacuation of the Sick and Wounded	FM 8-35
Field Behavior of NBC agents (Including Smoke and Incendiaries).....	FM 3-6

A-5. FIELD MANUALS (Con't).

First Aid for Soldiers..... FM 21-11
 Mountain Operations (How to Fight)..... FM 90-6
 NBC Contamination Avoidance FM 3-3
 NBC Decontamination FM 3-5
 NBC Protection FM 3-4
 Northern Operations FM 31-71
 Operational Terms and Symbols FM 101-5-1
 Vehicle Recovery Operations FM 20-22
 Visual Signals FM 21-60

A-6. TECHNICAL MANUALS.

Materials Used for Cleaning, Preserving, Abrading,
 and Cementing Ordnance Materiel and Related
 Items Including Chemicals..... TM 9-247
 Operator's, Unit, Direct Support, and General Support
 Maintenance Manual for Care, Maintenance,
 Repair and Inspection of Pneumatic Tires
 and Inner Tubes TM 9-2610-200-14
 Painting Instructions for Army Materiel TM 43-0139
 Procedures for Destruction of Equipment to Prevent
 Enemy Use (Mobility Equipment Command)..... TM 750-244-3

A-7. TECHNICAL BULLETINS.

Color, Marking, and Camouflage Painting of Military
 Vehicles, Construction Equipment, and Materiels
 Handling Equipment TB 43-0209
 Equipment Improvement Report and Maintenance
 Digest (U.S. Series Army Tank-Automotive
 Command) Tank-Automotive Equipment TB 430001-39-Series

A-8. OTHER PUBLICATIONS.

Army Medical Department Expendable/Durable Items..... CTA 8-100
 Expendable/Durable Items (Except Medical, Class V,
 Repair Parts, and Heraldic Items) CTA 50-970
 Prevention of Motor Vehicle Accidents AR 385-55

**APPENDIX B
COMPONENTS OF END ITEM AND
BASIC ISSUE ITEMS LISTS**

Section I. INTRODUCTION

B-1. SCOPE.

This appendix lists Components of End Item and Basic Issue Items for the M544E Forklift Truck to help you inventory Items required for safe and efficient operation.

B-2. GENERAL.

The Components of End Item and Basic Issue Items are divided into the following sections:

a. **Section II. Components of End Item List.** This listing is for Informational purposes only and is not authority to requisition replacements. These items are part of the end item, but are removed and separately packaged for transportation or shipment. As part of the end item, these items must be with the end item whenever it is issued or transferred between property accounts. Illustrations are furnished to assist you in Identifying the items.

b. **Section III. Basic Issue Items List.** These are the minimum essential items required to place the forklift truck in operation, to operate it, and to perform emergency repairs. Although shipped separately packaged, BII must be with the forklift truck during operation and whenever it is transferred between property accounts. The illustrations will assist you with hard-to-identify items. This manual is your authority to request/requisition replacement BII, based on TOE/MTOE authorization of the end item.

B-3. EXPLANATION OF COLUMNS.

Below is an explanation of columns found in the tabular listings:

a. **Column (1)-Illustration Number (Illus Number).** This column indicates the number of the illustration that shows the item.

b. **Column (2) - National Stock Number.** Indicates the National Stock Number assigned to the item and will be used for requisition purposes.

c. **Column (3)- Description.** Indicates the Federal item name and, if required, a minimum description in parentheses to identify and locate the item. The entry for each item ends with the Commercial and Government Entity (CAGE) Code in parentheses followed by the part number. Usable On Code indicates the vehicle to which the item is assigned. For an explanation of these codes, refer to paragraph C-3.

B-3. EXPLANATION OF COLUMNS (Con't).

d. **Column (4)-Unit of Measure (U/M).** Indicates the measure used in performing the actual operation/maintenance function. This measure is expressed by a two-character alphabetical abbreviation (e.g., ea, in, pr).

e. **Column (5) - Quantity Required (Qty/Rqr).** Indicates the quantity of the Item authorized to be used with the equipment.

Section II. COMPONENTS OF END ITEM

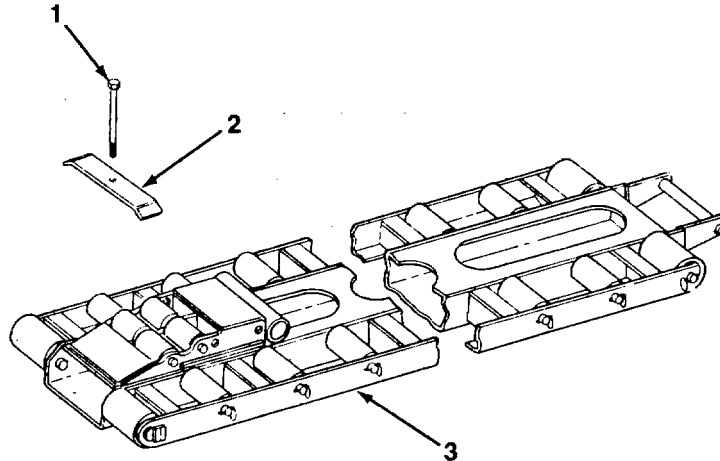

(1) ILLUS NUMBER	(2) NATIONAL STOCK NUMBER	(3) DESCRIPTION, CAGEC and Part Number	(4) Usable On Code U/M	(5) QTY Reqd
1		Capscrew' (75160) 08H4490	ea	2
2		Clamp (75160) T132616	ea	2
3		Conveyorized Fork Attachments (75160) AT 140760	ea	2

TA704533

Section III. BASIC ISSUE ITEMS

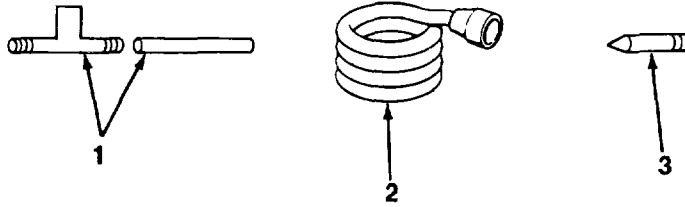

(1) ILLUS NUMBER	(2) NATIONAL STOCK NUMBER	(3) DESCRIPTION, CAGEC and Part Number	(4) Usable On Code U/M	(5) QTY Reqd
1		Adapter, STE/ICE Consisting of: Hose (75160) UN4617 Tee (75160) H83254	ea	1
2		Cable Assembly, Electrical: 110-Volt Extension (6Y402) 85(-0274	ea	1
3		Studs, Wheel Alining (75160) T108443	ea	3

TA704534

**APPENDIX C
ADDITIONAL AUTHORIZATION LIST**

Section I. INTRODUCTION

C-1. SCOPE.

This appendix lists additional items that you are authorized for the support of the M544E Forklift Truck.

C-2. GENERAL.

This list identifies items that do not have to accompany the forklift truck and that do not have to be turned in with it. These items are authorized to you by CTA, MTOE, TDA, or JTA.

C-3. EXPLANATION OF LISTING.

National Stock Numbers, descriptions, and quantities are provided to help you identify and request the additional items you require to support this equipment. If the item required differs for different models of this equipment, see the "Usable On Code" column for the applicable model or models. Usable On Codes are not applicable to this equipment.

Section II. ADDITIONAL AUTHORIZATION LIST

(1) NATIONAL STOCK NUMBER	(2) DESCRIPTION		(3)	(4)
	PART NUMBER & CAGEC	USABLE ON CODE	U/M	QTY AUTH
4230-01-133-4124	Decontamination Apparatus (81361) E5-51-527 M-13		ea	1
4210-00-889-2221	Extinguisher, Fire: Monobro, Hand (16236) CS 42100009 CEFN		ea	1

C-1/(C-2 Blank)

**APPENDIX D
EXPENDABLE/DURABLE SUPPLIES
AND MATERIALS LIST**

Section I. INTRODUCTION

D-1. SCOPE.

This appendix lists expendable/durable supplies and materials you will need to operate and maintain the M544E Forklift Truck. This listing is for informational purposes only and is not authority to requisition the listed items. These items are authorized to you by CTA 50-970, *Expendable/Durable Items (Except Medical, Class V, Repair Parts, and Heraldic Items)*, or CTA 8-100, *Army Medical Department Expendable / Durable Items*.

D-2. EXPLANATION OF COLUMNS.

a. **Column (1) - Item Number**. This number is assigned to the entry in the listing and is referenced in the "Initial Setup" of maintenance paragraphs or narrative instructions to identify the material needed (e.g., Dry cleaning solvent, Item 8, Appendix D).

b. **Column (2) - Level**. This column identifies the lowest level of maintenance that requires the listed item.

C-Operator/Crew

c. **Column (3)-National Stock Number**. This is the National Stock Number assigned to the item; use it to request or requisition the item.

d. **Column (4)- Description**. Indicates the Federal Item Name and, if required, a description to identify the item. The last line for each item indicates the Commercial and Government Entity (CAGE) in parentheses followed by the part number, if applicable.

e. **Column (5)-Unit of Measure (U/M)**. Indicates the measure used in performing the actual maintenance function. This measure is expressed by a two-character alphabetical abbreviation (e.g., ea, in., pr, gl). If the unit of measure differs from the unit of issue, requisition the lowest unit of issue that will satisfy your requirements.

Section II. EXPENDABLE/DURABLE SUPPLIES
AND MATERIALS LISTS

(1) ITEM NUMBER	(2) LEVEL	(3) NATIONAL STOCK NUMBER	(4) DESCRIPTION PART NUMBER AND CAGE	(5) UNIT OF MEAS
1	C	6850-00-926-2275	CLEANING COMPOUND: Windshield (81348) O-C-1901 1 Pint Bottle	pt
2	C	7930-00-282-9699	DETERGENT: General Purpose, Liquid (81346) MIL-D-16791 5 Gallon Container	gl
3	C	9150-00-935-9807 9150-00-935-9809 9150-00-935-9810	FLUID: Hydraulic. Petroleum Base (81349) MIL-H-6083 1 Quart Can 5 Gallon Can 55 Gallon Drum	qt gl gl
4	C	9140-00-286-5295 9140-00-286-5296 9140-00-286-5297	FUEL OIL, DIESEL: DF-2, Regular (81348) VV-F-800 5 Gallon Can 55 Gallon Drum, 16 Gage 55 Gallon Drum. 18 Gage	gl gl gl
5	C	9150-00-935-1017 9150-00-190-0904 9150-00-1900905 9150-00-190-0907 9150-00-530-7369	GREASE: Automotive and Artillery, GAA (81349) MIL-G-10924 14 Ounce Cartridge 14 Pound Can 6Y Pound Can 35 Pound Pail 120 Pound Drum	oz lb lb lb lb
6	6C	9150-00-186-6681 9150-00-188-9858 9150-00-189-6729	OIL: Lubricating, Internal Combustion Engine. Tactical Service, OE/HDO 30 (81349) MIL-L-2104 Quart Can 5 Gallon Can 55 Gallon Drum	qt gl gl
7	C	7920-00-205-1711	RAG: Wiping, Cotton and Cotton-Synthetic, White (58536) A-A-531 50 Pound Bale	lb lb
			D-2	

**Section II. EXPENDABLE/DURABLE SUPPLIES
AND MATERIALS LISTS (Con't)**

(1) ITEM NUMBER	(2) LEVEL	(3) NATIONAL STOCK NUMBER	(4) DESCRIPTION PART NUMBER AND CAGE	(5) UNIT OF MEAS
8	C	6850-00-110-4498 6850-00-664-5685 6850-00-281-1985 6850-00-274-5421 6850-00-110-4498 6850-00-285-8011	SOLVENT: Dry Cleaning, Type II (81349) P-D-680 1 Pint Can 1 Quart Can 1 Gallon Can 5 Gallon Can 55 Gallon Drum 55 Gallon Drum	pt qt gal gal gal gal

D-3/(D-4 Blank)

**APPENDIX E
STOWAGE AND SIGN GUIDE**

Section I. INTRODUCTION

E-1. SCOPE.

This appendix shows the location for stowage of equipment and material required to be carried on the M544E Forklift Truck.

E-2. GENERAL.

The following illustrations show the location of decals, stencils, and metal signs used on the forklift truck. Some are cautions or information that you need to safely operate the forklift truck.

Section II. STENCILS

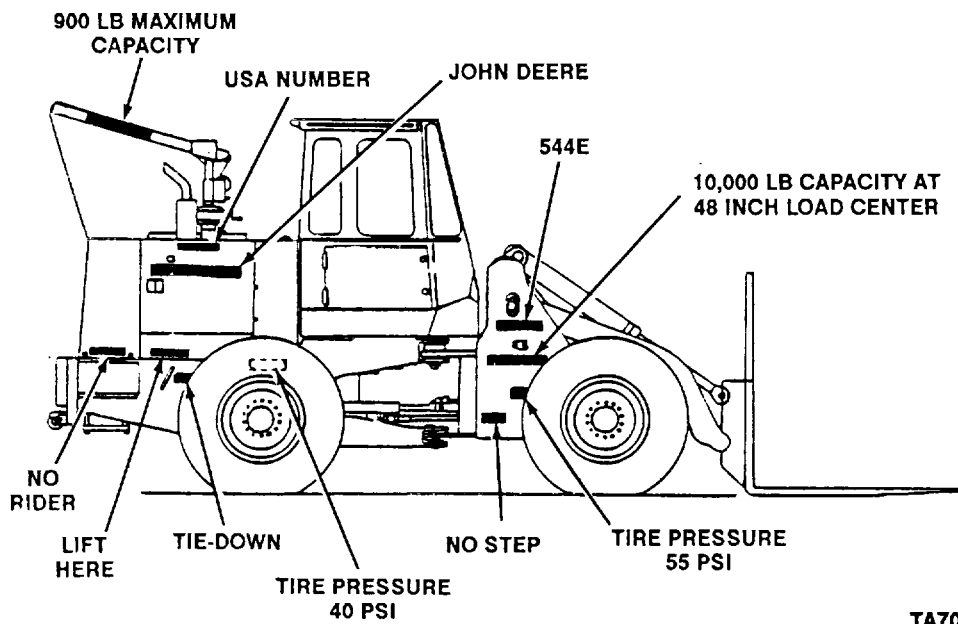
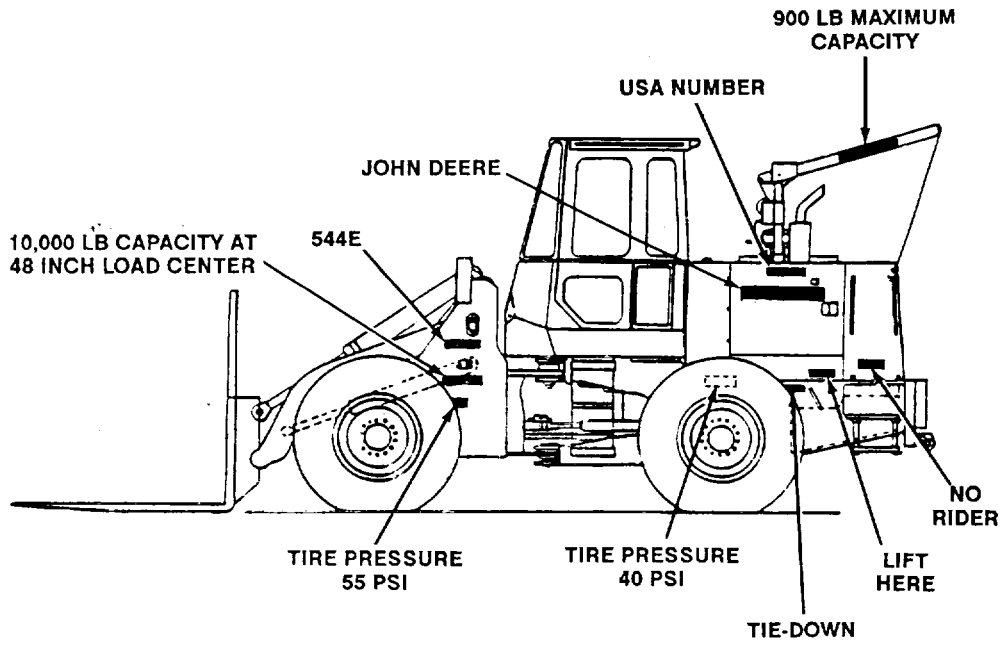

TA704535

TA704535

Section II. STENCILS (Con't)

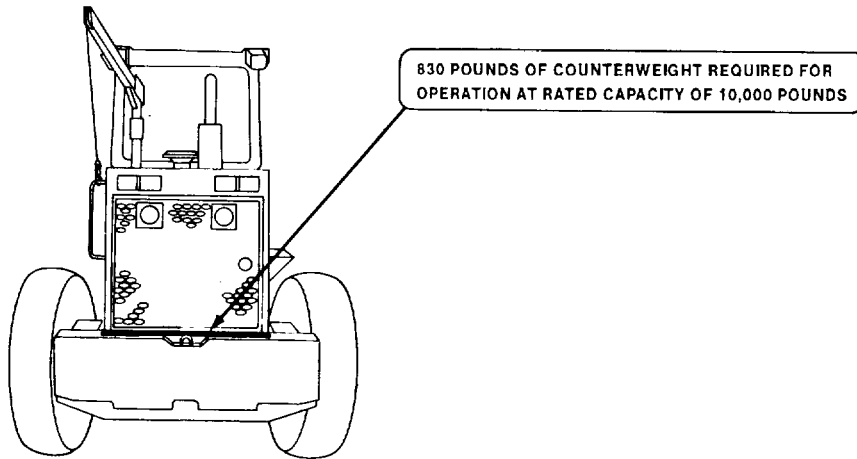
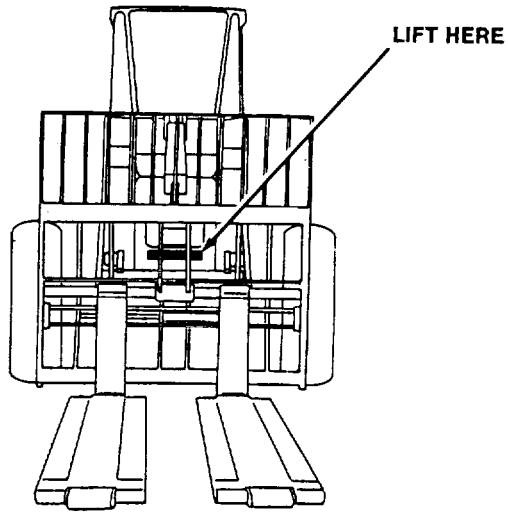

TA704536

Section III. DECALS

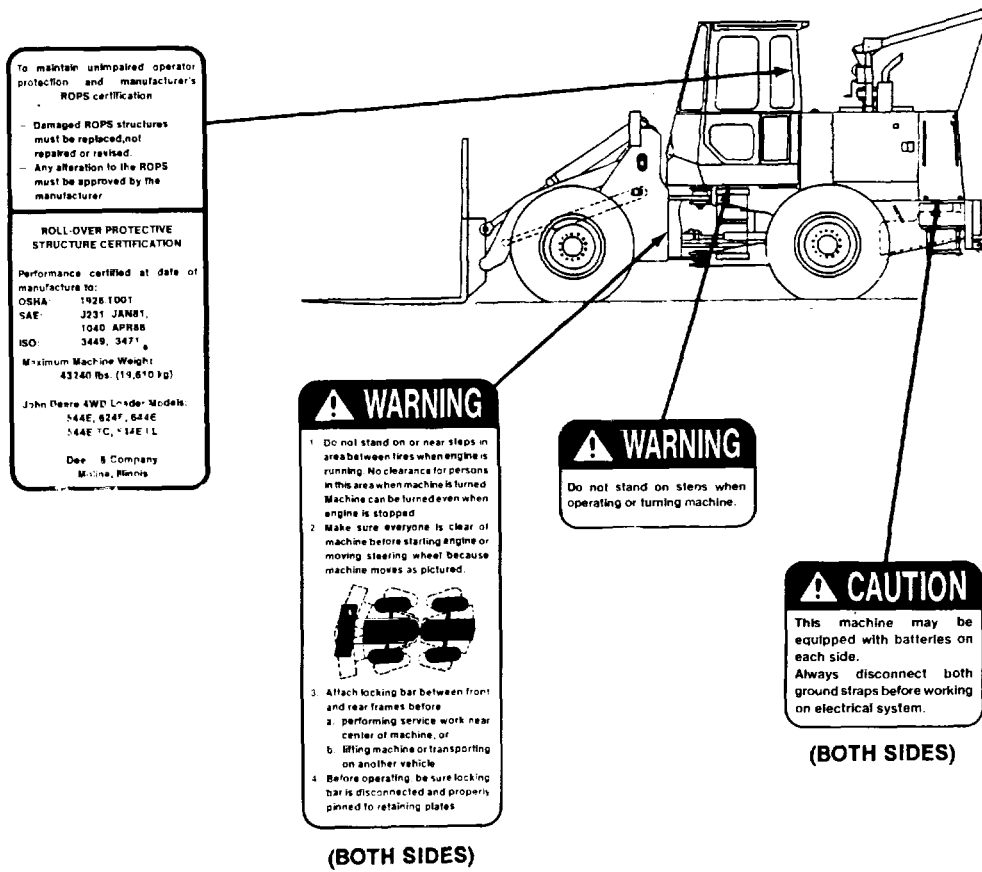

110 VOLTS ELECTRICAL RECEPTACLE

24 VOLTS SLAVE RECEPTACLE

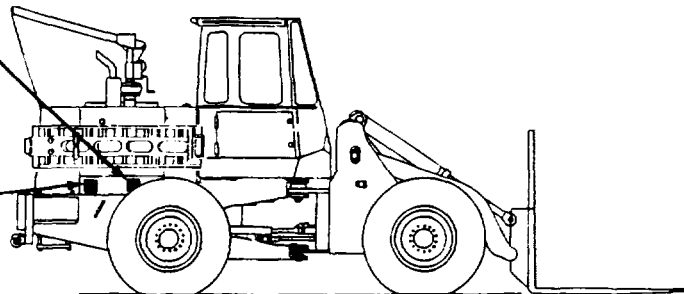

TA704537

TA704537

Section III. DECALS (Con't)

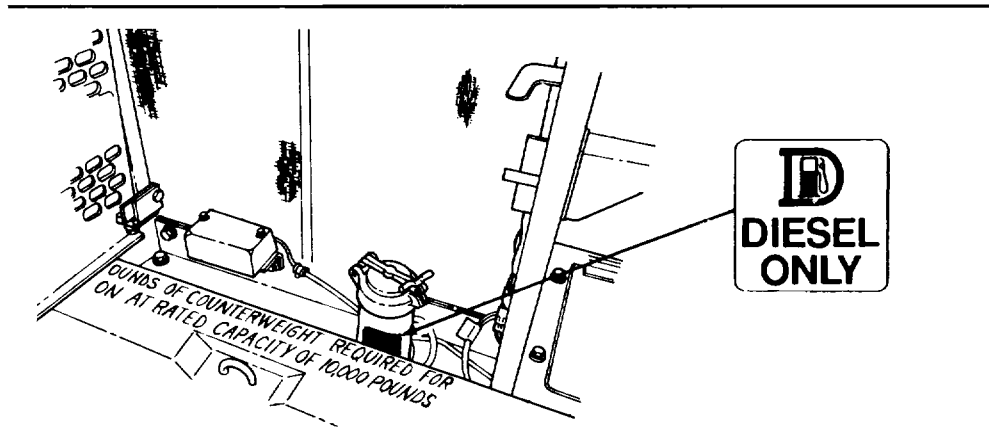
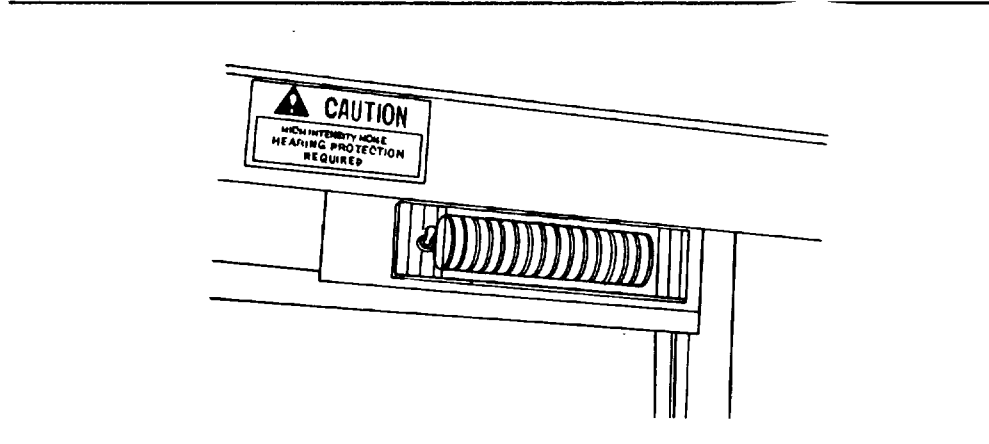
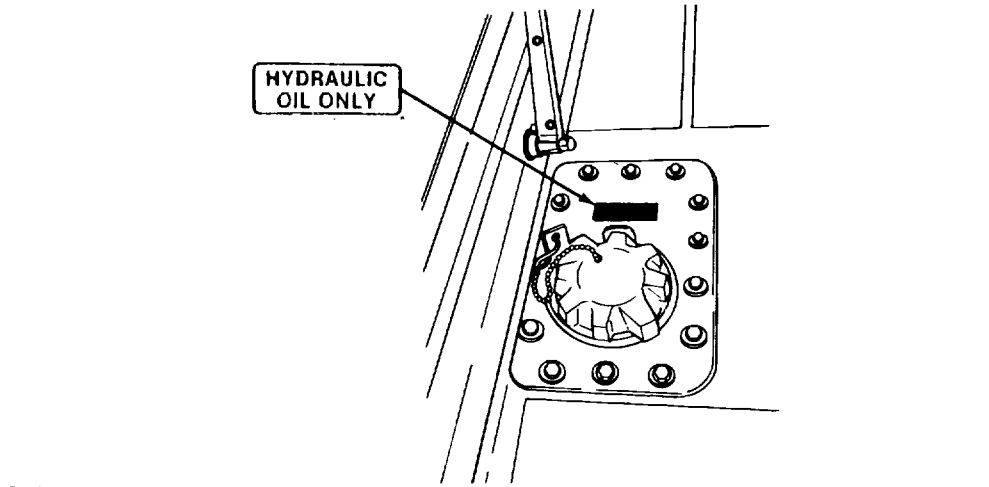

TA704538

TA704538

Section III. DECALS (Con't)

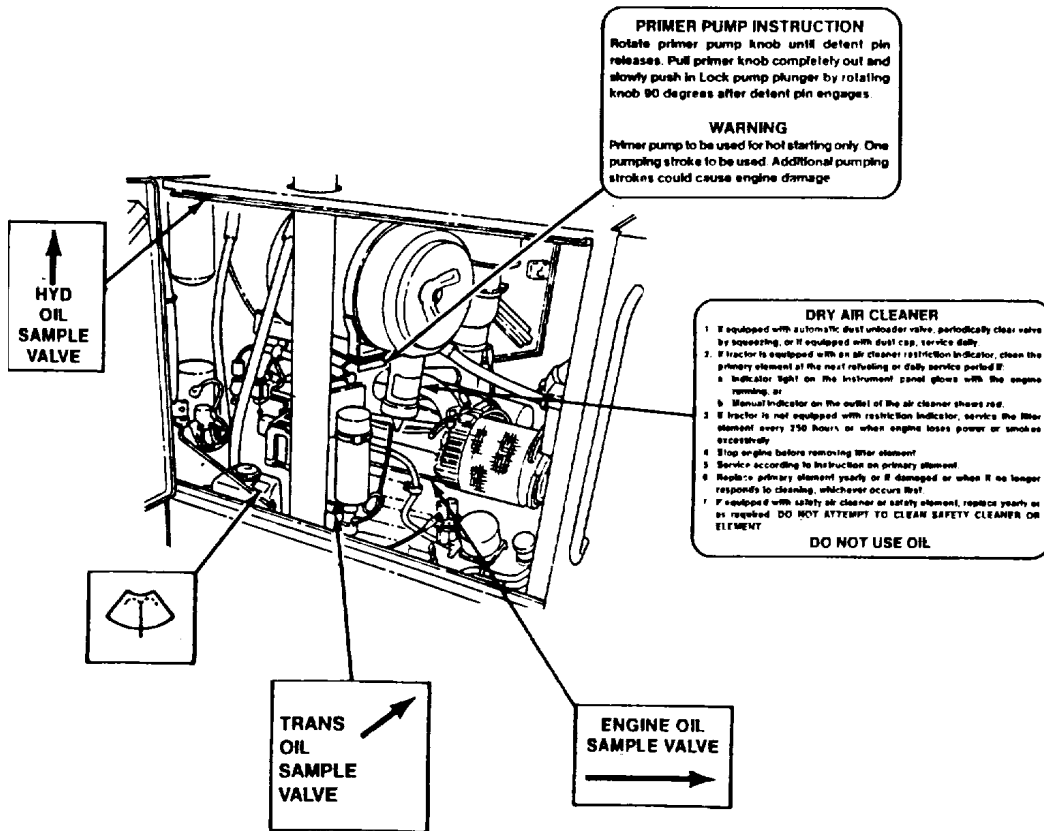
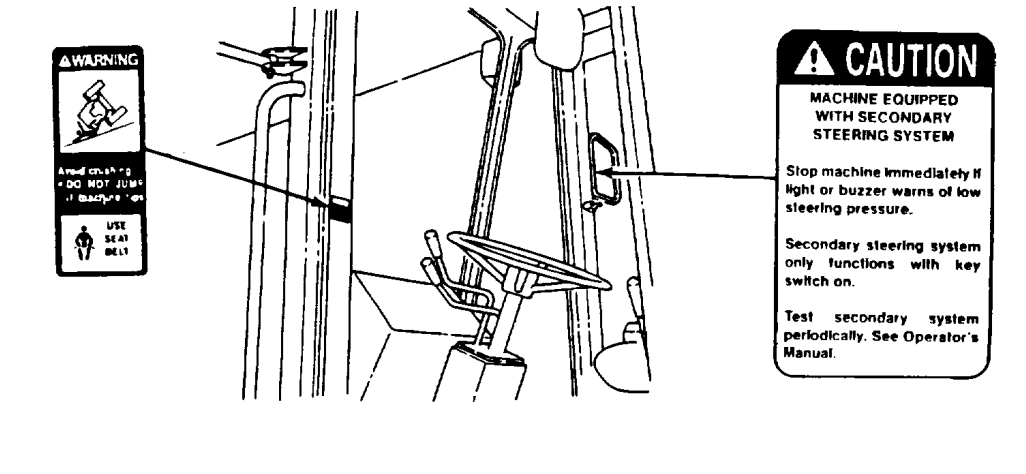

TA704539

TA704539

Section III. DECALS (Con't)

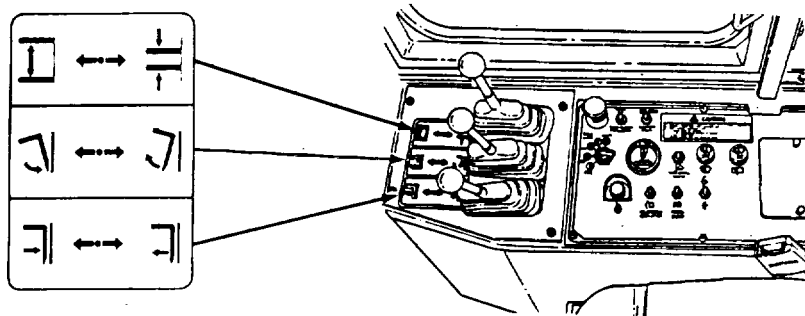
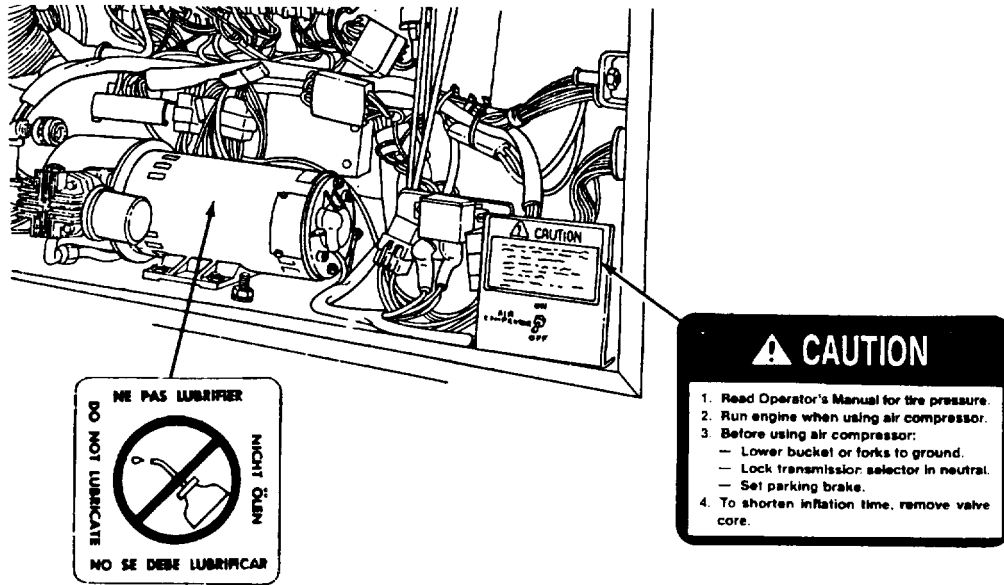

TA704540

TA704540

Section III. DECALS (Con't)

WARNING

Avoid injury from escaping fluid. Contents of this accumulator are under pressure.

- 1 Refer to proper Machine Model Technical Manual for disassembly or charging instructions and equipment required.
- 2 Charge with DRY NITROGEN only.

Maximum Working Pressure
22060 kPa (200 PSI)

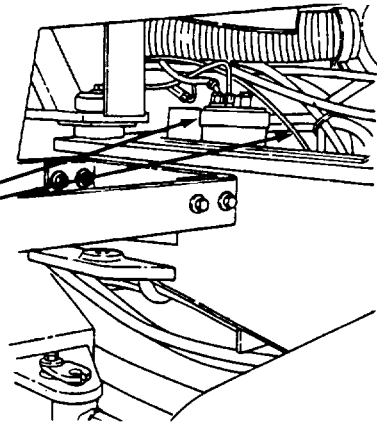

CAUTION

When stopping on inclines, push clutch cut-off switch on right instrument panel to engage position before releasing left service brake pedal to prevent loader from rolling down hill during transmission re-engagement cycle.

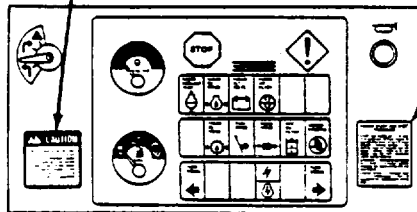

ENGINE START AND STOP PROCEDURE

START and WARM UP — At one-third speed setting crank engine 20 seconds maximum. Allow 2 minutes between cranking periods. Use starting fluid as required but not before cranking. Warm up at half speed and **DO NOT** accelerate rapidly during warm up.

STOPPING — Operate at half speed **NO LOAD** 2 minutes before stopping. Set speed to low idle and stop engine.

ENGINE STALL — Remove load, restart immediately. Run 30 seconds at half speed before adding load.

TA704541

TA704541

Section III. DECALS (Con't)

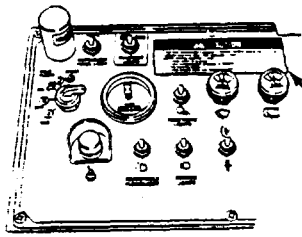

CAUTION

1. Read and understand Operator's Manual for safe machine operation.
2. Operate machine only from operator's seat
3. Before leaving operator's seat:
 - Lower bucket to ground.
 - Lock transmission selector in neutral.
 - Set parking brake.
 - Turn off engine.

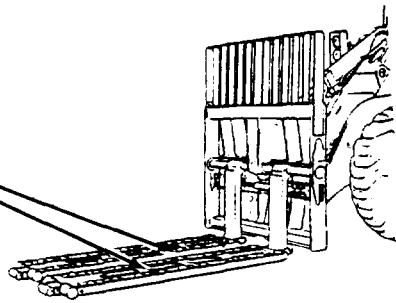

TA704542

Section IV. METAL SIGNS

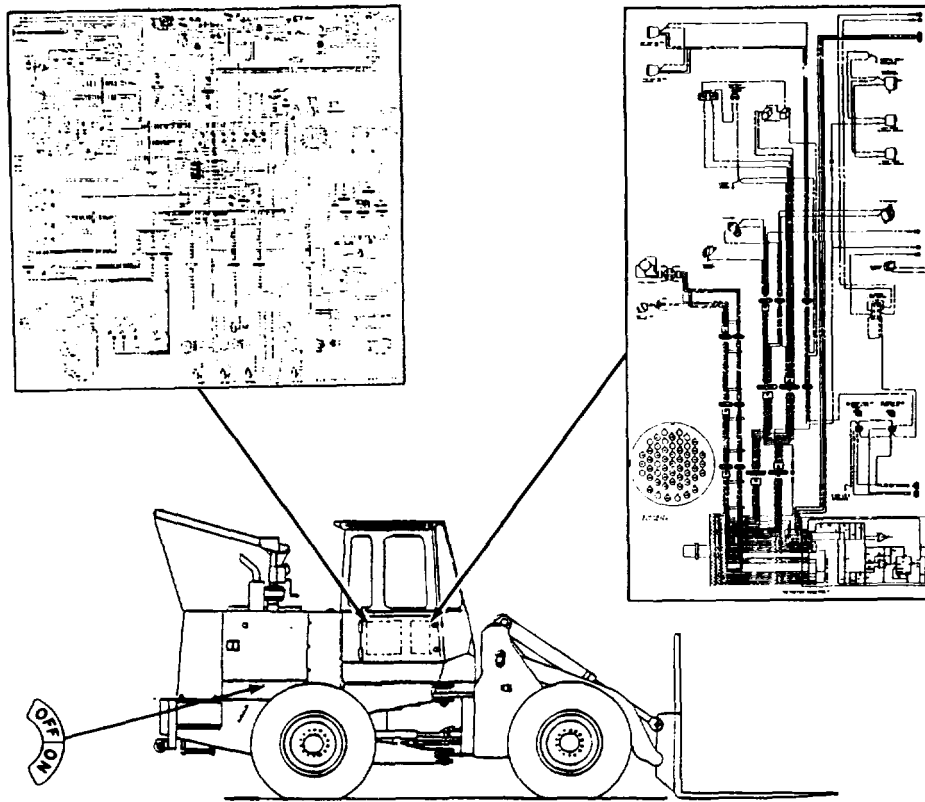

TA704543

Section IV. METAL SIGNS (Con't)

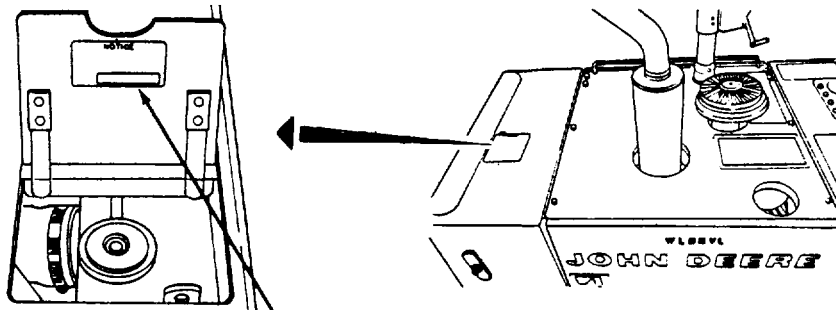

NOTICE
Cooling system contains glycol-type antifreeze.
Protects to -65°F (-54°C)
Signed _____
Date _____

TA704544

Section IV. METAL SIGNS (Con't)

PERIODIC MAINTENANCE
PERIODIC MAINTENANCE SCHEDULE FOR DIESEL ENGINE

ITEM	DESCRIPTION	INTERVAL	REMARKS
1	Oil Change	100 HRS	
2	Water Change	100 HRS	
3	Filter Change	100 HRS	
4	Valve Adjustment	100 HRS	
5	Timing Belt	100 HRS	
6	Water Pump	100 HRS	
7	Belts	100 HRS	
8	Brakes	100 HRS	
9	Steering	100 HRS	
10	Lighting	100 HRS	
11	Washers	100 HRS	
12	Grease	100 HRS	
13	Fluids	100 HRS	
14	Inspection	100 HRS	
15	General	100 HRS	

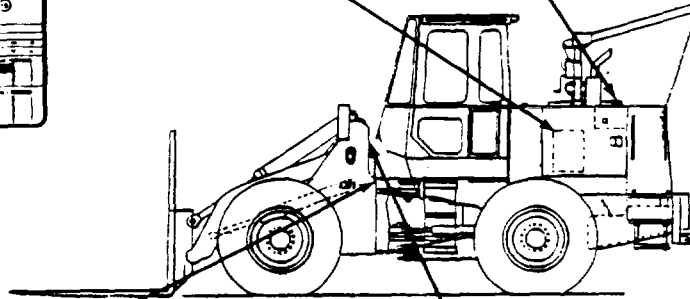
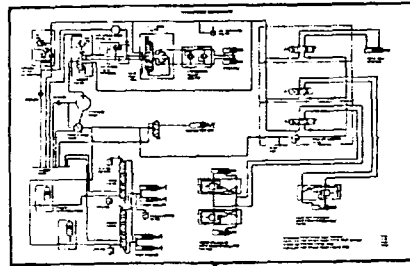

TRANSPORTATION DATA

USE FOR SHIPMENT, STORAGE, AND HANDLING INFORMATION.

CLASSIFICATION: HAZARDOUS NON-HAZARDOUS

NET WEIGHT: LB

GROSS WEIGHT: LB

DATE OF MANUFACTURE:

DATE OF REPAIR:

U.S. PROPERTY
TRUCK, LIFT, FORK

MODEL 244E YEAR OF MANUFACTURE

SER CAPACITY 10,000 LB AT 48 INCH

REGISTRATION NO. LOAD CENTER

NSN

WHEEL LOADING (NO PAYLOAD) CONT. NO. F09603 B9C 1093

FRONT WHEELS (EACH) 3,115 LB GROSS

REAR WHEELS (EACH) 7,000 LB GROSS

VEHICLE WT. 24,220 LB

WARRANTY 12 MO. DATE SHIP

COMPLIES WITH ANSI B56.8

JOHN DEERE DAVENPORT WORKS
 DAVENPORT, IOWA

TA704545

TA704545

INDEX

<i>Subject</i>	<i>Paragraph</i>	<i>Page</i>
A		
Abbreviations.....	1-7	1-2
Air Compressor	2-19	2-55
Air Filter:		
Cab:		
Fresh:		
Check	3-12b	3-20
Clean	3-12b	3-20
Recirculating:		
Check	3-12a	3-19
Clean	3-12a	3-19
Engine Primary:		
Check	3-11a	3-17
Clean	3-11a	3-17
Attachment Functions.....	2-17	2-50

B

Blackout Lights	2-21d	2-58
Bottle, Windshield Washer:		
Check.....	3-9	3-16
Fill	3-9	3-16
Brake, Service	1-12	1-10
Break-in, Engine:		
New.....	2-26	2-65
Rebuilt.....	2-26	2-65

C

Cab:		
Domelight.....	2-21f	2-59

INDEX

<i>Subject</i>	<i>Paragraph</i>	<i>Page</i>
Cab (Con't):		
Door	2-8a	2-34
Fan.....	2-22	2-60
Fresh Air Filter:		
Check	3-1 2b	3-20
Clean	3-12b	3-20
Recirculating Air Filter:		
Check	3-12a	3-19
Clean	3-12a	3-19
Window, Right Side.....	2-8b	2-35
Capabilities and Features, Equipment Characteristics.....	1-8	1-3
Cold Check Transmission Oil Level	3-7a	3-12
Compressor, Air	2-19	2-55
Controls and Indicators	2-2	2-1
Controls, Transmission:		
Direction Selector Lever.....	2-12	2-44
Speed Range Selector Lever.....	2-12	2-44
Conveyor Tips, Reverse.....	2-18c	2-54
Conveyorized Fork Attachment:		
Install.....	2-18	2-52
Remove.....	2-18	2-52
Reverse Conveyor Tips	2-18	2-52
Coolant:		
Level, Check	3-8a	3-14
Recovery Tank, Fill	3-8b	3-15
Corrosion Prevention and Control	1-3	1-1
Crane, On-board	1-16,	1-12,
	2-20	2-56
D		
Data, Equipment.....	1-10	1-7
Defroster.....	2-23	2-61

INDEX

<i>Subject</i>	<i>Paragraph</i>	<i>Page</i>
Direction Selector Lever	2-12	2-44
Domelight, Cab.....	2-21f	2-59
Door, Cab	2-8a	2-34
Drive Forklift Truck	2-13	2-45
Drive Train	1-11	1-10
Driver's:		
Seat.....	2-9	2-37
Seatbelt.....	2-10	2-39
Driving Tips.....	2-14	2-46
Dust Valve, Clean.....	3-11b	3-18
Dusty Areas, Operate.....	2-33	2-73
E		
Electrical	1-15	1-11
Emergency Flashers	2-21e	2-59
Engine:		
Break-in:		
New.....	2-26	2-65
Rebuilt.....	2-26	2-65
Oil:		
Add	3-6b	3-11
Level Check.....	3-6a	3-11
Primary Air Filter:		
Check	3-11a	3-17
Clean	3-11a	3-17
Shut Down	2-16	2-49
Start	2-11	2-40
Equipment:		
Characteristics, Capabilities, and Features	1-8	1-3
Data	1-10	1-7

INDEX

<i>Subject</i>	<i>Paragraph</i>	<i>Page</i>
Extreme:		
Cold.....	2-29	2-68
Heat	2-30	2-71
F		
Fan, Cab.....	2-22	2-60
Fill:		
Coolant Recovery Tank	3-8b	3-15
Radiator	3-8b	3-15
Filter:		
Cab:		
Fresh Air:		
Check.....	3-12b	3-20
Clean	3-12b	3-20
Recirculating Air:		
Check	3-12a	3-19
Clean	3-1 2a	3-19
Engine Primary Air:		
Check	3-11a	3-17
Clean	3-11a	3-17
Flashers, Emergency	2-21e	2-59
Fording	2-32	2-73
Fork Attachment, Conveyorized:		
Install.....	2-18	2-52
Remove.....	2-18	2-52
Reverse Conveyor Tips	2-18	2-52
Forklift Truck:		
Drive.....	2-13	2-45
Hydraulic System.....	1-11	1-11

INDEX

<i>Subject</i>	<i>Paragraph</i>	<i>Page</i>
Forklift Truck (Con't):		
Lock Frames	2-25	2-64
Park.....	2-15	2-47
Slave Start	2-27	2-65
Tow	2-28	2-67
Winterization Package	1-17	1-12
Frames, Lock Forklift Truck	2-25	2-64

H

Heater.....	2-23	2-61
Hot Check Transmission Oil Level	3-7c	3-12
Hydraulic:		
Oil:		
Level Check.....	3-10a	3-16
Reservoir, Fill.....	3-10b	3-16
System, Forklift	1-14	1-11

I

Indicators and Controls	2-2	2-1
Instrument Panel Lights.....	2-21c	2-58

L

Leakage Definitions.....	2-7	2-13
Lever:		
Direction Selector.....	2-12	2-44
Speed Range Selector.....	2-12	244

INDEX

<i>Subject</i>	<i>Paragraph</i>	<i>Page</i>
Lights:		
Blackout	2-21d	2-58
Instrument Panel.....	2-21c	2-58
Service	2-21a	2-58
Work	2-21b	2-58
Location and Description of Major Components	1-9	1-4
Lock Forklift Truck Frames	2-25	2-64
Lubrication Order.....	3-2	3-1
M		
Major Components, Location and Description	1-9	1-4
Mud, Operate.....	2-31	2-73
N		
New Engine Break-in.....	2-26	2-65
O		
Oil:		
Add, Engine	3-6b	3-11
Check, Engine Level	3-6a	3-11
Hydraulic:		
Fill Reservoir.....	3-10b	3-16
Level Check.....	3-10a	3-16

INDEX

<i>Subject</i>	<i>Paragraph</i>	<i>Page</i>
Oil (Con't):		
Transmission:		
Add	3-7b	3-12
Cold Check	3-7a	3-12
Hot Check	3-7c	3-12
On-board Crane	1-16, 2-20	1-12, 2-56
Operate In:		
Dusty Areas	2-33	2-73
Extreme:		
Cold	2-29	2-68
Heat	2-30	2-71
Mud	2-31	2-73
Sandy Areas.....	2-33	2-73
Snow	2-31	2-73
P		
Park Forklift Truck	2-15	2-47
PMCS	2-7	2-12
Primary Air Filter, Engine:		
Check.....	3-11a	3-17
Clean.....	3-11a	3-17
R		
Radiator, Fill	3-8b	3-15
Rebuilt Engine Break-in.....	2-26	2-65
Recovery Tank, Coolant, Fill	3-8b	3-15

INDEX

<i>Subject</i>	<i>Paragraph</i>	<i>Page</i>
Refueling	3-13	3-21
Reservoir, Fill Hydraulic Oil	3-10b	3-16
Reverse Conveyor Tips	2-19c	2-54
Right Side Cab Window	2-8b	2-35

S

Sandy Areas, Operate	2-33	2-73
Seat, Driver's	2-9	2-37
Seatbelt, Driver's	2-10	2-39
Service:		
Brake	1-12	1-10
Lights	2-21a	2-58
Shut Down Engine	2-16	2-49
Signals, Turn	2-21e	2-59
Slave Start Forklift Truck	2-27	2-65
Snow, Operate	2-31	2-73
Speed Range Selector Lever	2-12	2-44
Start Engine	2-11	2-40
Steering	1-13	1-11
Symptom Index, Troubleshooting	3-5	3-3
System:		
Drive Train	1-11	1-10
Electrical	1-15	1-11
Forklift Hydraulic	1-14	1-11
Service Brake	1-12	1-10
Steering	1-13	1-11

T

Tips, Driving	2-14	2-46
---------------------	------	------

INDEX

<i>Subject</i>	<i>Paragraph</i>	<i>Page</i>
Tow Forklift Truck	2-28	2-67
Train, Drive	1-11	1-10
Transmission:		
Controls:		
Direction Selector Lever	2-12	2-44
Speed Range Selector Lever.....	2-12	2-44
Oil:		
Add	3-7b	3-12
Level:		
Cold Check.....	3-7a	3-12
Hot Check.....	3-7c	3-12
Troubleshooting:		
Procedure	Table 3-1	3-4
Symptom Index.....	3-5	3-3
Turn Signals	2-21e	2-59

W

Washer:		
Bottle, Windshield:		
Check	3-9	3-16
Fill	3-9	3-16
Window	2-24	2-63
Window:		
Right Side Cab.....	2-8b	2-35
Washers.....	2-24	2-63
Wipers.....	2-24	2-63
Windshield Washer Bottle:		
Check.....	3-9	3-16
Fill	3-9	3-16

INDEX

<i>Subject</i>	<i>Paragraph</i>	<i>Page</i>
Winterization Package.....	1-17	1-12
Wipers, Window	2-24	2-63
Worklights	2-21b	2-58

By Order of the Secretary of the Army:

GORDON R. SULLIVAN
General, United States Army
Chief of Staff

Official:

MILTON H. HAMILTON
Administrative Assistant to the
Secretary of the Army

05649

Distribution:

To be distributed in accordance with DA Form 12-25-E, Block 5916,
requirements for TM 10-3930-659-10.

*U.S. GOVERNMENT PRINTING OFFICE:1994-546-017/00015

RECOMMENDED CHANGES TO EQUIPMENT TECHNICAL PUBLICATIONS



THEN... JOT DOWN THE DOPE ABOUT IT ON THIS FORM, CAREFULLY TEAR IT OUT, FOLD IT AND DROP IT IN THE MAIL!

SOMETHING WRONG WITH THIS PUBLICATION?

FROM: (PRINT YOUR UNIT'S COMPLETE ADDRESS)

DATE SENT

PUBLICATION NUMBER

PUBLICATION DATE

PUBLICATION TITLE

BE EXACT... PIN-POINT WHERE IT IS

PAGE NO.

PARA-GRAPH

FIGURE NO.

TABLE NO.

IN THIS SPACE TELL WHAT IS WRONG AND WHAT SHOULD BE DONE ABOUT IT:

TEAR ALONG PERFORATED LINE

PRINTED NAME, GRADE OR TITLE, AND TELEPHONE NUMBER

SIGN HERE:

DA FORM 2028-2
1 JUL 79

PREVIOUS EDITIONS ARE OBSOLETE.

P.S.—IF YOUR OUTFIT WANTS TO KNOW ABOUT YOUR RECOMMENDATION MAKE A CARBON COPY OF THIS AND GIVE IT TO YOUR HEADQUARTERS.

THE METRIC SYSTEM AND EQUIVALENTS

LINEAR MEASURE

- 1 Centimeter = 10 Millimeters = 0.01 Meters = 0.3937 Inches
- 1 Meter = 100 Centimeters = 1,000 Millimeters = 39.37 Inches
- 1 Kilometer = 1,000 Meters = 0.621 Miles

SQUARE MEASURE

- 1 Sq Centimeter = 100 Sq Millimeters = 0.155 Sq Inches
- 1 Sq Meter = 10,000 Sq Centimeters = 10.76 Sq Feet
- 1 Sq Kilometer = 1,000,000 Sq Meters = 0.386 Sq Miles

CUBIC MEASURE

- 1 Cu Centimeter = 1,000 Cu Millimeters = 0.06 Cu Inches
- 1 Cu Meter = 1,000,000 Cu Centimeters = 35.31 Cu Feet

LIQUID MEASURE

- 1 Milliliter = 0.001 Liters = 0.0338 Fluid Ounces
- 1 Liter = 1,000 Milliliters = 33.82 Fluid Ounces

TEMPERATURE

- $5/9 (^{\circ}\text{F} - 32) = ^{\circ}\text{C}$
- 212° Fahrenheit is equivalent to 100° Celsius
- 90° Fahrenheit is equivalent to 32.2° Celsius
- 32° Fahrenheit is equivalent to 0° Celsius
- $9/5 \text{ } ^{\circ}\text{C} + 32 = \text{ } ^{\circ}\text{F}$

WEIGHTS

- 1 Gram = 0.001 Kilograms = 1,000 Milligrams = 0.035 Ounces
- 1 Kilogram = 1,000 Grams = 2.2 lb.
- 1 Metric Ton = 1,000 Kilograms = 1 Megagram = 1.1 Short Tons

APPROXIMATE CONVERSION FACTORS

TO CHANGE	TO	MULTIPLY BY
Inches	Centimeters	2.540
Feet	Meters	0.305
Yards	Meters	0.914
Miles	Kilometers	1.609
Square Inches	Square Centimeters	6.451
Square Feet	Square Meters	0.093
Square Yards	Square Meters	0.836
Square Miles	Square Kilometers	2.590
Acres	Square Hectometers	0.405
Cubic Feet	Cubic Meters	0.028
Cubic Yards	Cubic Meters	0.765
Fluid Ounces	Milliliters	29.573
Pints	Liters	0.473
Quarts	Liters	0.946
Gallons	Liters	3.785
Ounces	Grams	28.349
Pounds	Kilograms	0.454
Short Tons	Metric Tons	0.907
Pound-Feet	Newton-Meters	1.356
Pounds Per Square Inch	Kilopascals	6.895
Miles Per Gallon	Kilometers Per Liter	0.425
Miles Per Hour	Kilometers Per Hour	1.609
TO CHANGE	TO	MULTIPLY BY
Centimeters	Inches	0.394
Meters	Feet	3.280
Meters	Yards	1.094
Kilometers	Miles	0.621
Square Centimeters	Square Inches	0.155
Square Meters	Square Feet	10.764
Square Meters	Square Yards	1.196
Square Kilometers	Square Miles	0.386
Square Hectometers	Acres	2.471
Cubic Meters	Cubic Feet	35.315
Cubic Meters	Cubic Yards	1.308
Milliliters	Fluid Ounces	0.034
Liters	Pints	2.113
Liters	Quarts	1.057
Liters	Gallons	0.264
Grams	Ounces	0.035
Kilograms	Pounds	2.205
Metric Tons	Short Tons	1.102
Newton-Meters	Pound-Feet	0.738
Kilopascals	Pounds Per Square Inch	0.145
Kilometers Per Liter	Miles Per Gallon	2.354
Kilometers Per Hour	Miles Per Hour	0.621

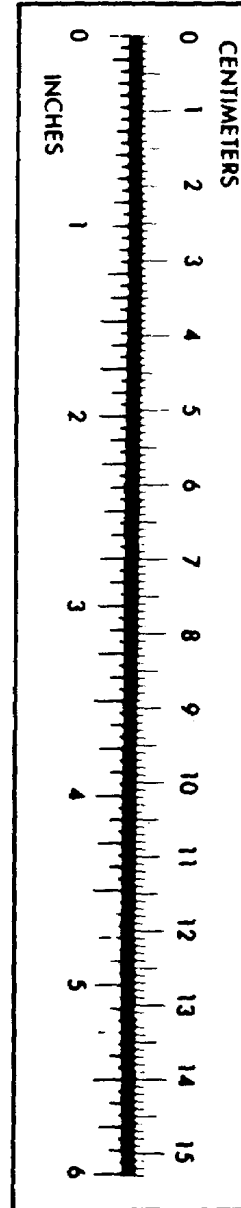

Pin: 071978-000